

CROP WATER PRODUCTIVITY AND IRRIGATION CROP WATER PRODUCTIVITY AS INFLUENCED BY MAIZE (*Zea mays* L.) GENOTYPES AND IRRIGATION QUALITY USING AQUACROP MODEL

AKRAM ABBAS KHALAF and MURAD JAN M. M. NOORI

Dept. of Soil and water science, College of Agriculture, University of Duhok, Kurdistan Region –Iraq

Received: May 2, 2018; Accepted for Publication: February, 2019)

ABSTRACT

The effects of different irrigation water qualities and maize genotypes on the water-yield relationships were studied by using AquaCrop model. The study area is located in Duhok city with latitude, longitude and elevation of 36°51'42.5"N, 42°51'57.6"E and 473m (a.m.s.l), respectively. A drip irrigated maize (*Zea mays* L.) field experiment was conducted to test the goals of the research project for the growing season 2015 and irrigation qualities of Khanic surface, Ground water and Bitter water with maize genotypes of Sangria, Neroz, and IK58 x un 44052 maize genotypes were used in the study water-yield relationships such as crop water productivity (CWP), irrigation crop water productivity (ICWP) for grain yield was calculated. The most important results of this study as follow: The (CWP_{GY}) and (ICWP_{GY}) were varied depending on (IWQ) and their qualities. The highest values were for Khanic water and the lowest values obtained under bitter water, the values of CWP_{GY} and ICWP_{GY} under the effect of maize genotypes were the highest values for IK58 x un 44052 and the lowest value obtained under sangria. The interaction between the effects of irrigation water qualities and Maize genotype for both CWP_{GY} and ICWP_{GY} showed the greatest amount were obtained under I₁G₂ ; meanwhile the lowest values was obtained from I₃G₁, The coefficient of determination (R²) for the measured and simulated Crop Water Productivity (CWP) and (ICWP) of yield parameter, grain yield, using AquaCrop model were equal to 0.9978-0.998 respectively under the effect of studied factors of irrigation water qualities and Maize genotypes.

KEYWORDS: AquaCrop model, Irrigation water quality, Crop water productivity, irrigation crop water productivity, maize genotype.

1. INTRODUCTION

The availability of water in Iraqi Kurdistan region is below the desired level. This will lead to water shortage in the future, as water plays an important role in repair and production improvement, therefore, it is necessary to increase the usage of the lands, capturing rainfall in more efficient way for water storage as well as irrigation uses. In addition to usage, another natural water source such as ground water especially in supplementary irrigation is mostly required. It is very necessary to change the irrigation management practices to increase the production per unit of water consumed instead of improvement of production per unit area (Feres and Soriano, 2006).

The increase in water sources scarcity led the growers start to search for more efficient irrigation methods. Where there is an expectation at 2050 the storage of annual global water will be 640

billion m³ (Spears, 2003). As a result of insufficient irrigation water supply, the effect of water shortage appears in most of Middle East and African countries even for a short term.

The irrigation sector is one of the most water consumptive sectors consisting approximately 71% of the fresh water around the world, for this reason the water scarcity events have obtain a great importance in both agendas (political and scientific) (a text book of Agronomy, 2010).

The specific variation in the crop and the region are very significant to understand, measure, and order. The aim of this study is to provide an estimation of water productivity from a number of researches that covers main cereal crops and a large technological extensions from substances to system with high production (Sadras *et al.*, 2010).

Maize is considered as one of the most important feeding crops across the world where it can be used by the humans as food and for animals as feed (Chandrasekaran *et al.*, 2010).

AquaCrop which has been developed by FAO (2009), produced as one of the most powerful software's that used during the situations of water scarcity to help consultants, project managers, agronomists, irrigation engineers, and even farm manager by defining guidelines to maximize the crop water productivity for irrigated production systems, as well as rainfed (Raes *et al.*, 2009). Increasing the water productivity means reducing water requirements for crop production which can be defined as the amount of water in addition to rainfall that must be applied to meet a crops evapotranspiration needs without significant reduction in yield (Van Hoorn, 1970). In view of above considerations, this study was conducted and the specific objective was to provide an estimation of measured and simulated Crop Water

Productivity (CWP) and Irrigation Crop Water Productivity (ICWP) of grain yield, maize genotypes (Sangria, Neroz, and IK58 x un 44052) and different irrigation water qualities (IWQ) of Khanic surface, Ground water and Bitter water.

MATERIALS AND METHODS

1. Experimental site description

The research was executed between (April – August) 2015 at the farm of Field crops Department, College of Agriculture / University of Duhok at Sumael site where latitude, longitude and elevation 36°51'42.5"N, 42°51'57.6"E and 473m (a.m.s.l) respectively nearly 12 km to the west of the center of Duhok city / Kurdistan Region - Iraq (Fig 1)



Fig. (1): Maps of the Study Area Location (A) Duhok Governorate (B) College of Agriculture/ University of Duhok (C) Field of Study.

2. Land preparation and soil sampling

The chosen land was prepared by ploughing twice, perpendicular to each other using mould board plow on 25th March, 2015 while the smoothing and leveling processes was done 31st March, 2015.

Soil samples were taken from the land by digging a soil profile to a depth of 120 cm on 18th

March, 2015 the samples were taken from 0-30, 30-60, 60-90, and 90-120 cm depths. Between 2kg the samples were taken at different depths and placed in a plastic bag after air drying, grinding and sieving (sieve opening diameter of 2mm), and then stored in the laboratory waiting for analysis of some soil chemical and physical properties. In addition to these samples, other samples of

undisturbed soil were taken from the same depths for the purpose of determination of bulk density using steel core with 4cm diameter and 5cm dimensions.

3. Soil and Water analysis

3.1. Soil physical analyses

The determination of soil texture using Hydrometer method is described by (Gee and

Bauder, 1986; Ryan *et al.*, 2001) table (1) and bulk density measurement using core method described by (Blake and Hartge, 1986). Soil moisture content was determined by pressure plate using pressure under different pressures ranged between (33-1500) kpa.

Table (1): Some physical properties of the soil at research

		Depth (cm)			
Soil property		(0-30)	(30-60)	(60-90)	(90-120)
pH at 25 °C in(1:1) extract	Unit	7.95	7.99	7.99	7.96
EC at 25 °C	dS m ⁻¹	0.454	0.365	0.332	0.315
Sand	g kg ⁻¹	4.38%	5.14%	3.12%	2.46
Silt		45.21%	46.71%	55.72%	56.48
Clay		50.41%	48.15%	41.16%	41.06
Soil texture		Silty clay	Silty clay	Silty clay	Silty clay
Bulk density	g cm ⁻³	1.392	1.443	1.501	1.451
θ _m at 33	kpa	32.31	30.41	28.31	28.88
θ _m at 1500		20.16	19.25	18.14	19.00

3.2. Soil Chemical analyses

Chemical analyses started after preparing an extract from 1:2 saturated soil paste after 24hr duration (table 2).

The measurement of EC was made using EC-meter model HI 9635 according to (Wilcox, 1950). The pH was measured from the same extract using pH-meter model HI 9023 as described by (Jackson, 1958). The Soluble Calcium and Magnesium content was measured using titrimetric method with (0.01N) EDTA, of (Jackson, 1973). Sodium and Potassium content was measured by flame photometer (model JENWAY PFP 7) according to (Standford and English, 1949; Toth *et al.*, 1948). The Carbonate, Bicarbonate and Chloride content were measured by titrimetric method with (0.01 N) H₂SO₄ as

(Page *et al.*, 1982). The Sulphate content was determined by subtracting method, of (Abu Sharar, 1976). The Calcium Carbonate content was determined by Calcimeter method, (Hesse, 1972). The active CaCO₃ was determined according to (Kozhekov and Yakovleva, 1977). The determination of soil organic matter was done by the Walkley and Black method using K₂Cr₂O₇ (1N) according to (Allison, 1965). Total available soil (N₂) (NO₃ and NH₄) was determined using Kjeldahl method as mentioned by (Ryan *et al.*, 2001). The soil phosphorous was determined spectrometrically using Olsen's method at 880 nm wave range as described by (Rowell, 1996). The CEC was calculated by using ammonium acetate, based on (Hesse, 1972).

Table (2): Some chemical properties of the study soil

Soil property	Unit	Depth (cm)			
		(0-30)	(30-60)	(60-90)	(90-120)
Available N	mg. Kg ⁻¹	105.95	106.25	106.38	106.33
Available P	mg. Kg ⁻¹	4.88	4.85	4.88	4.86
K ⁺	Soluble Cations (mmol _c L ⁻¹)	0.20	0.16	0.18	0.18
Ca ²⁺		1.66	1.65	1.67	1.68
Mg ²⁺		1.03	1.05	1.07	1.07
Na ⁺		0.62	0.60	0.61	0.62
Cl ⁻	soluble anions (mmol _c L ⁻¹)	0.50	0.55	0.58	0.59
HCO ₃ ⁻		2.33	2.30	2.34	2.35
CO ₃ ⁼		trace	Trace	Trace	Trace
CaCO ₃	g. Kg ⁻¹	217.6	216.9	217.7	217.8
Active CaCO ₃	g. Kg ⁻¹	109.9	111.2	110.8	110.8
O.M	g. Kg ⁻¹	1.633	1.77	1.520	1.451
CEC	Cmol _c kg ⁻¹	31.35	31.43	31.45	31.46
pH at 25 °C in(1:1) extract		7.95	7.99	7.99	7.96
EC at 25 °C	dS. m ⁻¹	0.454	0.365	0.332	0.315

To calculate the ET₀ for the period 1997-2014 and compare it with ET₀ for the 2015 growing season, different equations (e.g., *Blaney-Criddle* and *Penman-Montieth* equations in addition to ET calculator software) was applied.

The monthly ET_c was obtained by using the following formula (Allen *et al.*, 2005):

$$ET_c = k_c * ET_0 \dots \dots \dots \text{Eq. [1]}$$

Where:

ET_c = Calculated crop evapotranspiration (mm day⁻¹).

k_c = Crop coefficient .

ET₀ = Reference evapotranspiration (mm day⁻¹).

4. Studied elements

4.1. Experimental Design

The study was carried out in factorial experiment of split plots in Randomize Completely Block Design (RCBD).

The study was executed with two factors and three replicates, the sources of irrigation factor were implemented in the main plots, and the genotypes of Maize crop factor were implemented in subplots. Each replicate consists of nine experimental units (3replicates * 9plots =27 experimental unit). On a field area of ≈ 460m² (40.5m length * 11.30m width), each plot area was

equal to 5.25m² (2.5m length * 2.1m width) and contained four rows separated by a distance between of 0.70m.

First Factor = Irrigation Water Source with three levels as:

IWS1= Treatment irrigated with surface water source near Khanic, from catchment area of Aski Mosul dam (untreated water).

IWS2 = Treatment irrigated with ground water source from well of good quality located near to the studied area beside the College of Agriculture.

IWS3 = Treatment irrigated with Bitter ground water source from well located at the village of Bazalan approximatally 3.3 km far from College of Agriculture.

Second Factor = Genotype of maize (*Zea mays* L.) Field crop with three types as:

G₁ = Treatment planted with Sangria genotype of corn field crop.

G₂ = Treatment planted with Neroz of corn field crop.

G₃ = Treatment planted with hybrid IK58 x un44052 of corn field crop with three replicates. Total units = A * B * C = 3 * 3 * 3 = 27 unit. (A = irrigation water sources, B = Maize genotypes and C = replicates)

Each replicate was divided to 3 separate groups in order to be irrigated separately and each group was sown randomly with the genotypes. Area occupied by plant was obtained by multiplying distance between plant and distance between rows. Area occupied by plant was 0.14m² as illustrated in Fig. (2).

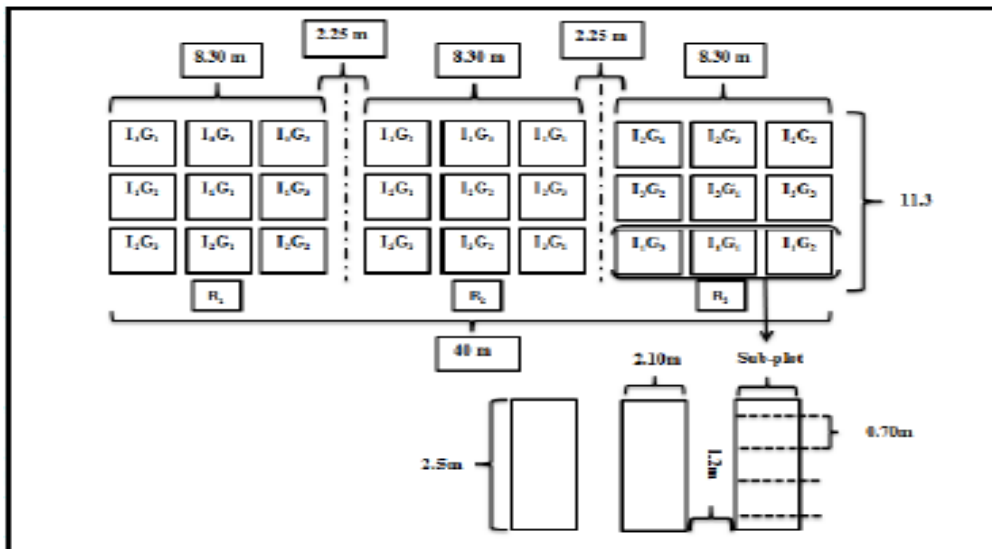

Fig.(2): Layout of the field experiment at Sumael/ University of Duhok/ College of Agriculture

4.2. Actual crop evapotranspiration (ET_a)

Actual crop evapotranspiration (ET_a) was determined by soil water budget method which is described by (Farahani *et al.*, 2009). Measuring or estimating all the components of water balance equation for a control volume of soil profile up to 90cm soil depth (root zone depth) the equation below was used:

$$ET_a = P + I - D - R \pm \Delta S \dots \dots \dots \text{Eq. [2]}$$

Where:

P= Precipitation (mm),

I= Irrigation (mm),

D= Deep percolation below root zone (mm),

R= Runoff (mm) and

ΔS= The change in stored water content (mm) of the soil profile.

The amounts of deep percolation D and surface runoff R were assumed to be negligible or zero there were no runoffs as well as the amount of irrigation was under the field capacity due to the using of drip irrigation system.

4.3. Water- Yield relationship

The calculation of water productivity (CWP) and irrigation water productivity (ICWP) was obtained by using the following equations:

$$CWP(\text{kg/m}^3) = Y_a / ET_a \dots \dots \dots \text{Eq. [3]} \text{ (Molden et al., 2010)}$$

$$ICWP(\text{kg/m}^3) = Y_a / I \dots \dots \dots \text{Eq. [4]} \text{ (Molden et al., 2010)}$$

Where:

Y_a = actual yield in (kg /m²).

ET_a = actual crop evapotranspiration (m³/m²).

I = irrigation water applied (m^3/m^2).

5. AquaCrop Model

5.1. Description of AquaCrop Model

AquaCrop is a crop water productivity model developed by the Land and Water Division of FAO. It simulates yield response to water of herbaceous crops. AquaCrop is a companion tool for wide applications including yield prediction under climate change scenarios. As in other models, aqua-crop model structures its soil-crop atmosphere continuum by including (i) the soil, with its water balance; (ii) the plant, with its growth, development, and yield processes; and (iii) the atmosphere, with its thermal regime, rainfall, evaporative demand, and carbon dioxide

concentration. Additionally, some management aspects are explicit, with emphasis on irrigation, the levels of soil fertility as they affect crop development, water productivity, crop adjustments to stresses, and final yield. Although grounded on basic and complex biophysical processes (Smith, 2000). AquaCrop uses a relatively small number of explicit parameters and largely-intuitive input variables.

5.2. Soil and weather data

The dominant soil series at the site is silty clay with 1% of slope. The soil was well drained, in general, with a deep-water table. The weather data for the experimental site is presented in Table (3).

Table (3): Growing season (April, 15th - August 10th) 2015 weather summary for Sumael location (research location)

Station	Growing Season	Ave. Daily max. Temp. (C ^o)	Ave. Daily min. Temp. (C ^o)	Rainfall (mm)	Ave. Daily RH (%)	Ave. Solar Radiation (w/m ²)	wind speed (m/s)
Collage of Agriculture	APR.	22.7	11.6	0.74	59	215.9	2.62
	MAY.	33.07	14.9	0.36	37.3	262.71	3.25
	JUN.	38.16	19.1	0.06	26.4	279.5	3.63
	JUL.	43.49	22.9	0	21.4	264.19	2.9
	AUG.	42.38	21.6	0	25.2	225.16	3.09

6. Data Collection and Statistical Analysis

The data were gathered and analyzed statistically using Soil Water characteristics software (SPAW) and Microsoft Office (Excel) program to find out their significance at both probabilities $P \leq (0.05$ and $0.01)$ by applying least significant difference (LSD) and also to determine the correlations between variables.

RESULTS AND DISCUSSION

Results:

1. Actual crop Evapotranspiration (ET_a)

Under no water stress ($ET_m = ET_a$) the daily and cumulative maximum evapotranspiration was measured which was equal to (744, 728 and 728) mm for (IWS1, IWS2 and IWS3) respectively, starting from the emergence stage till harvesting.

2. Calculated crop evapotranspiration (ET_c)

The results of calculated evapotranspiration (ET_c), reference evapotranspiration (ET_0) and crop

coefficient (kc) for maize at Duhok governorate for 2015 were given in table (4).

Reference evapotranspiration (ET_0) was calculated in mm day^{-1} using each Blaney-Criddle and Penman-Montieth equations from ET calculator software for 1997 to 2015 (table 5).

Evapotranspiration (ET_c) and the average ET_c were calculated in mm day^{-1} according to the equation (1), ET_a also calculated using water balance method. By Comparing the periods for ET_a and ET_c , It is derived that water requirement for the mentioned dates predominately the restricted period (1st -31st May, 1st-30th June, 1st - 31st July) can be estimated, while the estimation of water requirement was less accurate for the periods between (15th -30th April and 1st - 10th August), this variation may be resulted from the change in the temperature which increased progressively during April and August which made a variation at the beginning and the end of the growing season. After the calculation of ET_m

and ET_a two parameters include: (k_c and k_s were calculated using the following equations):

$$ET_m = k_c ET_0 \dots \dots \dots Eq. [5]$$

$$ET_a = k_c k_s ET_0 \dots \dots \dots Eq. [6]$$

Where is:

k_s is the soil water availability factor or soil water stress coefficient.

The average of k_c were calculated and was equal to 0.75 and this is almost coincided with those which founded by (Tawfeek, 2006) table (5).

ET_a is directly proportional with the amount of applied irrigation water and/or water use and this refers to no much water loss in the experiment.

Table (6) shows the amounts of water which applied during the irrigation process, total Number of irrigation, irrigation water saving, ET_a and ET_a/ET_m ratios.

Table (4): References evapotranspiration (ET_0) $mm\ day^{-1}$, calculated evapotranspiration (ET_c) $mm\ day^{-1}$ and k_c from 2014 to 2015 in Duhok

2015										
Periods	Days	k_c *	Water Balance equation	SCS Blaney-Criddle		Penman-Montieth		ET Calculator		Average
			ET_m	ET_0	ET_c	ET_0	ET_c	ET_0	ET_c	ET_c
15-30Apr.	16	0.4	2.92	3.39	1.36	5.18	2.07	4.17	1.67	2.55
1-31 May.	31	0.7	5.33	5.88	4.12	6.38	4.66	7.43	5.20	6.99
1-30 Jun.	30	1.1	8.02	7.78	8.56	7.69	8.46	9.29	10.2	13.62
1-31 Jul.	31	0.8	6.06	9.56	7.65	7.48	6.21	9.68	7.74	10.80
1-10 Aug.	10	0.7	5.11	8.50	5.95	7.42	5.19	12.2	8.54	9.84

Table (5): Actual evapotranspiration (ET_a), cumulative reference evapotranspiration (ET_0), k_c and k_s for the growing season at different irrigation levels (I_1 , I_2 and I_3) during 2014-2015 in Duhok

Years	Irrigation treatments	2015										1997-2014					
		SCS Blaney-Criddle		Penman-Montieth		ET Calculator		Average		SCS Blaney-Criddle		Penman-Montieth		ET Calculator		Average	
		ET_0	$k_c k_s$	ET_0	$k_c k_s$	ET_0	$k_c k_s$	k_c	k_s	ET_0	$k_c k_s$	ET_0	$k_c k_s$	ET_0	$k_c k_s$	k_c	k_s
I_1	743.85	851.32	0.873	811.99	0.916	961.04	0.774	0.75	1	878.08	0.847	835.18	0.890	679.12	1.095	0.75	1
I_2	728.47	851.32	0.855	811.99	0.897	961.04	0.758	0.75	0.98	878.08	0.829	835.18	0.872	679.12	1.072	0.75	0.98
I_3	728.17	851.32	0.855	811.99	0.896	961.04	0.757	0.75	0.98	878.08	0.829	835.18	0.871	679.12	1.72	0.75	0.98

Table (6): Total number of irrigation. Irrigation water applied, water use and ET_a of maize for the three irrigation treatments

Source of Irrigation	No. of	WS initial (mm)	WS last (mm)	ΔS (mm)	I (mm)	WU (mm)	IW saving (%)	ET_a (mm)	ET_a/ET_m
IWS ₁	20	114.72	57.89	56.83	800.68	915.40	0.00	743.85	1.00
IWS ₂	20	114.72	50.69	64.04	792.51	907.23	0.99	728.47	0.98
IWS ₃	20	114.72	45.80	68.93	797.09	911.82	1.00	728.17	0.98

3. Water-Yield relationships

3.1. Crop water productivity (CWP) and irrigation crop water productivity (ICWP) of Grain Yield (GY) as affected by Irrigation Water Source (IWS and Maize Genotype (MG)

3.1.1. Field Measurement

The results indicate that CWP_{GY} and $ICWP_{GY}$ were significantly ($p \leq 0.01$) affected by irrigation water sources, maize genotypes as well as their interaction (I*G).

The CWP_{GY} and $ICWP_{GY}$ were varied depending on IWS. The data of CWP_{GY} (1.84,

1.40, 1.18 kg/m^3) and $ICWP_{GY}$ (1.71, 1.29, 1.08 kg/m^3) for (I₁, I₂, and I₃), were obtained respectively (Fig.4).

the amounts of CWP_{GY} and $ICWP_{GY}$ under the effect of maize genotypes were showed in figure (4.16) the highest value of CWP_{GY} was 1.56 kg/m^3 for G₃ treatment and the lowest value obtained under G₁ treatment and was equal to 1.31 kg/m^3 ; meanwhile the greatest value of $ICWP_{GY}$ was 1.44 kg/m^3 for G₃ treatment and the minimum value also obtained from G₁ treatment and was equal to 1.21 kg/m^3 .

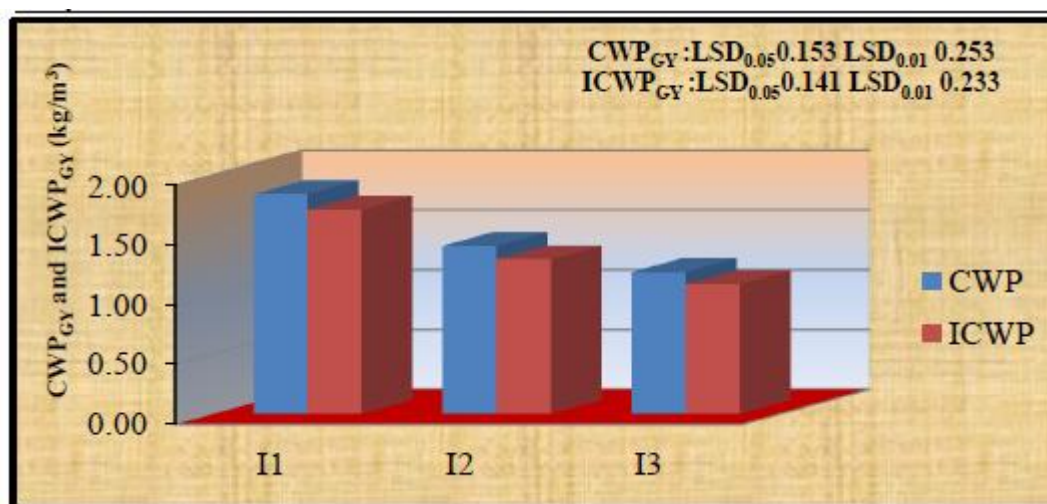

Fig (4): Effect of irrigation water source on CWP_{GY} and $ICWP_{GY}$.

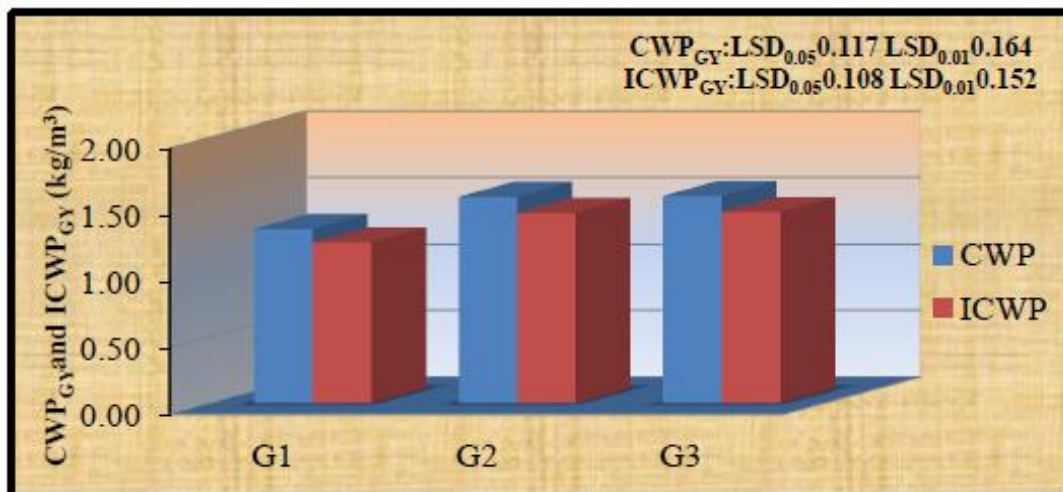

Fig (5): Effect of maize genotype on CWP_{GY} and ICWP_{GY}.

The interaction between the effects of irrigation water sources and Maize genotype for both CWP_{GY} and ICWP_{GY} were showed in the figure (6). The greatest amount of CWP_{GY} and ICWP_G

Y were obtained under I₁G₂ treatment of 1.97 and 1.83 kg/m³, respectively, meanwhile the lowest values was obtained from I₃G₁ treatment and was equal 1.06 and 0.97 kg/m³ respectively.

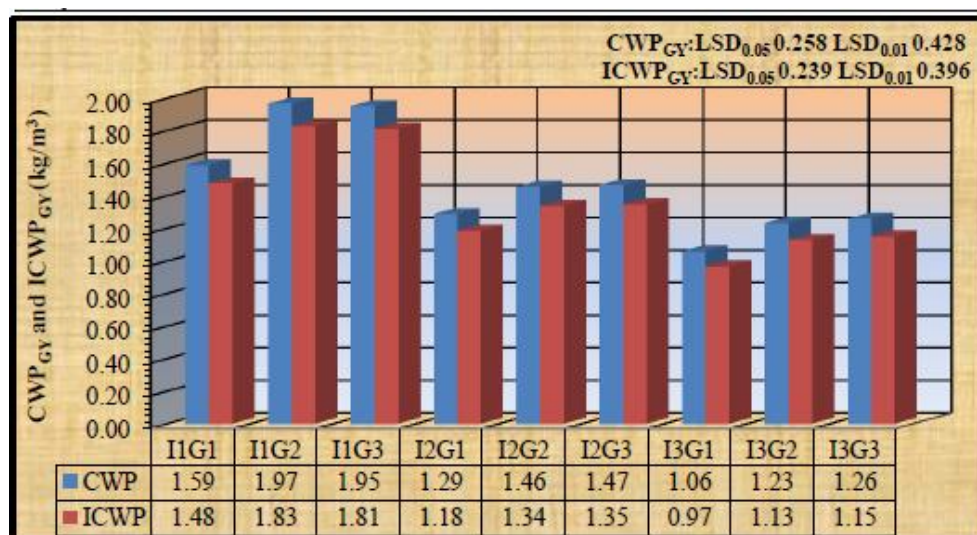

Fig (6): The interaction effect of irrigation water source and maize genotype on CWP_{GY} and ICWP_{GY}.

3.3. Relationship between measured and simulated CWP_{GY} and ICWP_{GY}

Figure(7) shows the data of CWP_{GY} and ICWP_{GY} which simulated by AquaCrop model under the effect of irrigation water source. The highest CWP_{GY} and ICWP_{GY} which was acquired

under I₁ treatment and was equal to 1.649 and 1.532 kg/m³. respectively, meanwhile the lowest amount was 1.164 and 1.082 kg/m³. The obtained data clarify that there was high compatibility (R²= 0.997 for CWP_{GY} and 0.998 for ICWP_{GY}) between the measured and simulated results.

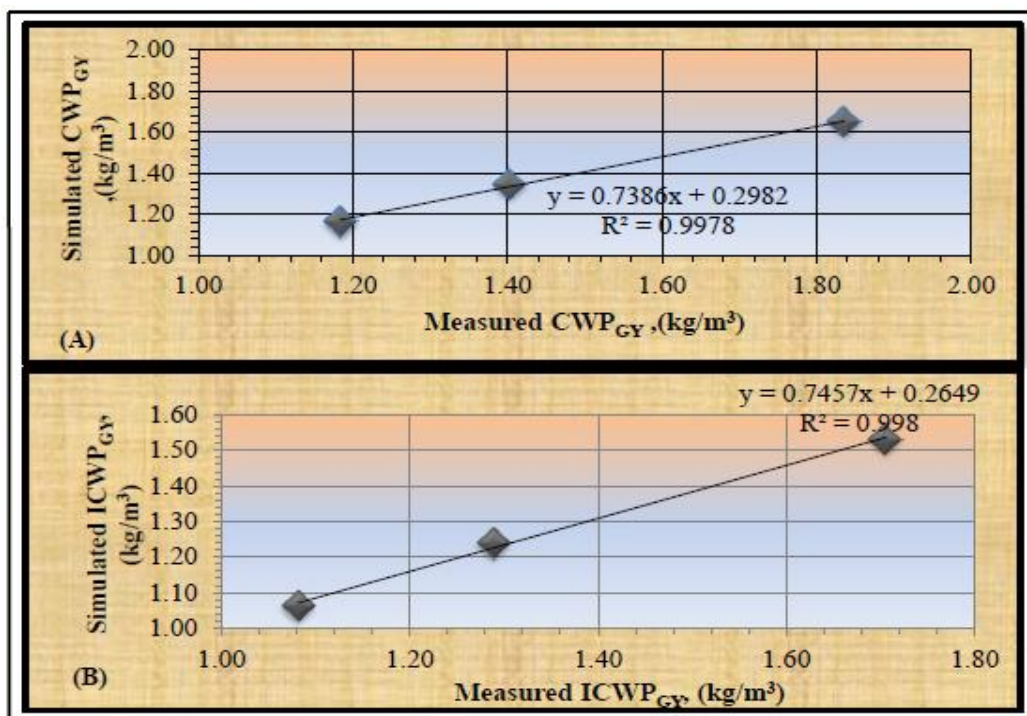
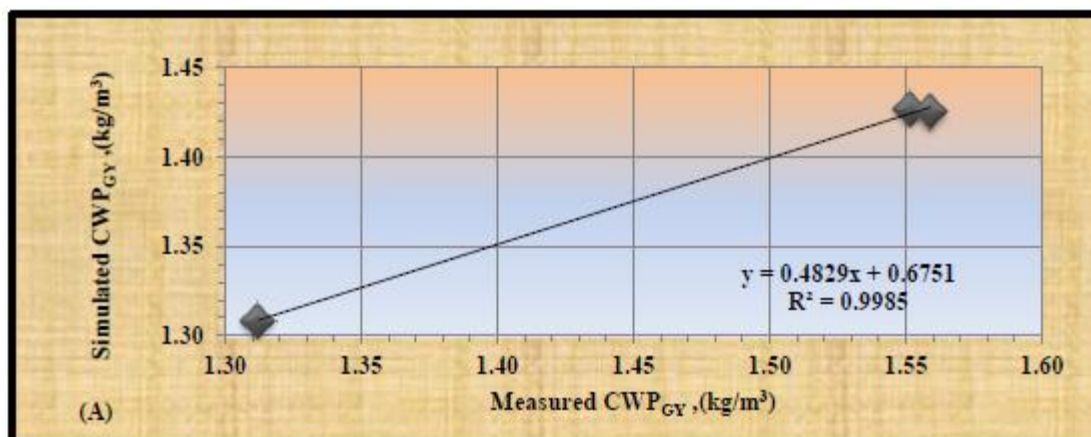

Fig (7)

A,B : Relationship between measured and simulated CWP_{GY} and ICWP_{GY} as affected by Irrigation Water Source.

On the other hand, the simulated data for both CWP_{GY} and ICWP_{GY} under the effect of maize genotype were shown in figure (8). The greatest values were 1.427 and 1.315 kg/m³ acquired under G₂ meanwhile the lowest value were 1.309 and 1.206 kg/m³ for CWP_{GY} and ICWP_{GY} respectively.



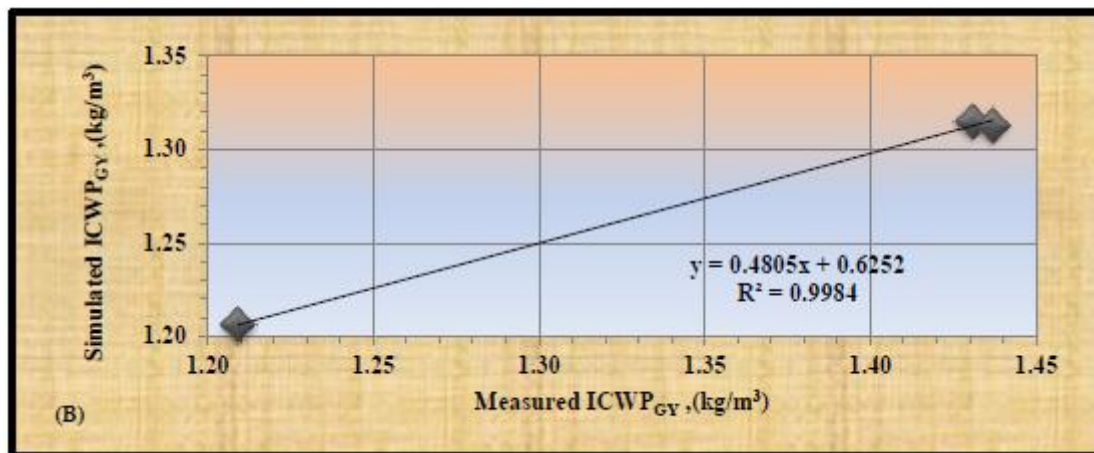
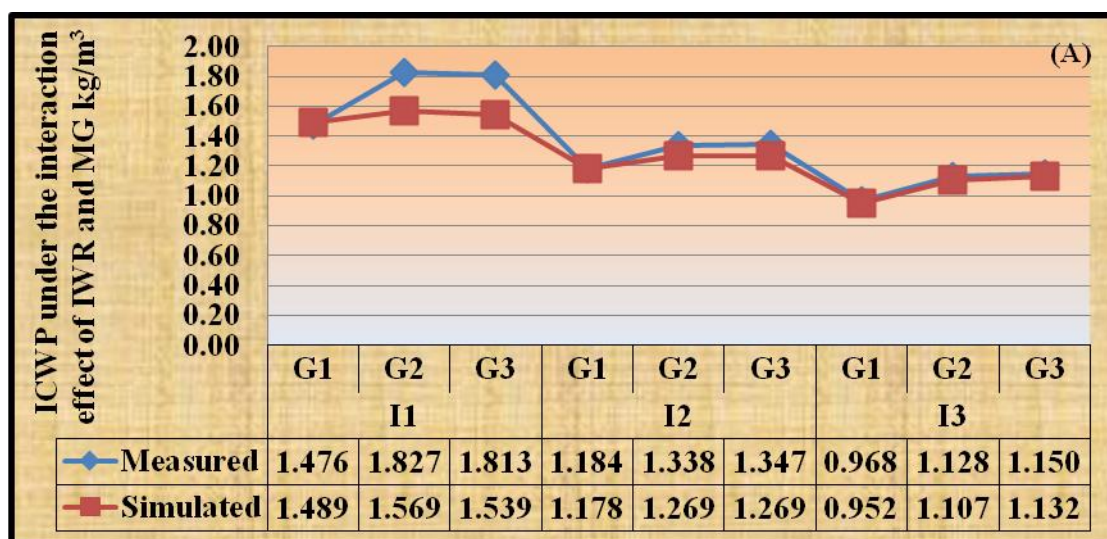

Fig (8) A,B : Relationship between measured and simulated CWP_{GY} and $ICWP_{GY}$ as affected by maize genotype.

The simulated interaction between the effects of irrigation water sources and maize genotype ($I*G$) for both CWP_{GY} and $ICWP_{GY}$ were introduced in the figure (9). The greatest amount of CWP_{GY} and $ICWP_{GY}$ were obtained under I_1G_2 as

it in measured results of 1.68 and 1.56 kg/m^3 respectively, meanwhile the lowest values was obtained from I_3G_1 treatment and was equal 1.04 and 0.95 kg/m^3 for CWP_{GY} and $ICWP_{GY}$ respectively.



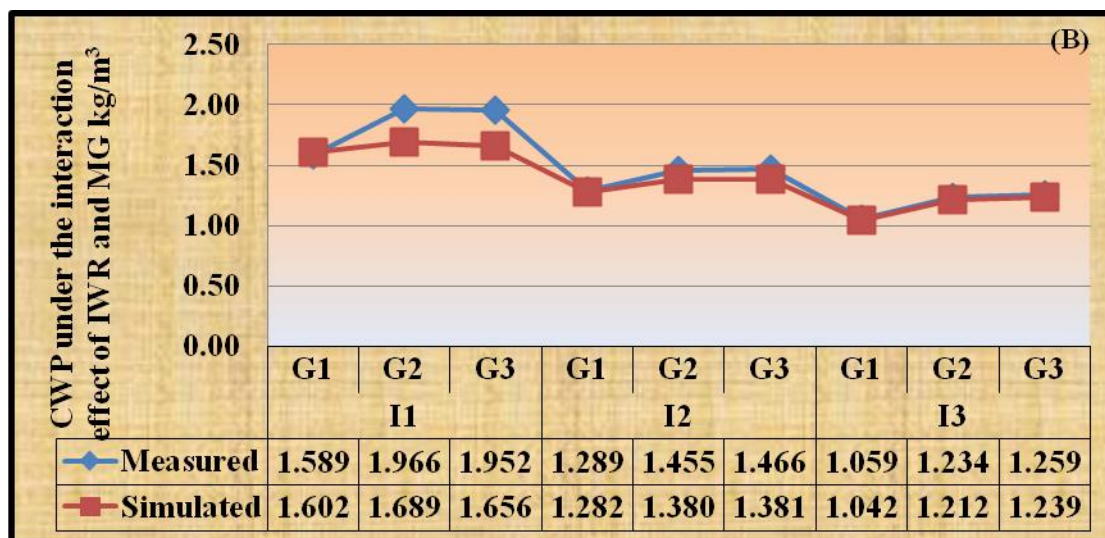

Fig (9) A,B : Relationship between Measured and Simulated grain yield CWP_{GY} and $ICWP_{GY}$ under the interaction effect of IWS and MG

DISCUSSION

Water-Yield relations

Kijne et al. (2003) reported the great defying confrontation the agricultural sector is to use less water for producing more food increasing crop water productivity.

Above ground biomass, dry mass and grain yield-based water productivity (CWP and $ICWP$) under irrigation water source (salinity) treatments is showed, values of CWP and $ICWP$ was statistically higher at irrigation water sources of lower salinities, whereas, CWP and $ICWP$ reached its minimum at IWS lower salinity; (Azazian and Sapaskhah, 2014) indicated that the optimum level of CWP and $ICWP$ could be obtained with saving some volume of irrigation water where it was significantly decreased with increasing salinity levels of irrigation water sources as 18.6 and 26%, respectively.

Interaction effect of experimental factors on CWP and $ICWP$ is presented, where the effect of treatment interactions on CWP and $ICWP$, the IWS (salinity conditions) and maize genotype had greater CWP and $ICWP$ at the application of surface water source (I1) under each irrigation treatments. Similar result was indicated by (Sepaskhah and Tafteh, 2012) for MG they reported that under water shortage and lower salt levels higher WP obtained; the results which obtained by them under different irrigation water sources were in correspondence with the findings of CWP and $ICWP$.

The highest values of CWP and $ICWP$ were acquired from fresh water application (lower salinity); the environmental conditions, as well as genetic properties effects the accessibility for highest values of CWP and $ICWP$, (Sepaskhah and Tafteh, 2012).

Mansouri-far *et al.* (2010) indicated that CWP and $ICWP$ under different environmental similar to the environmental conditions of the study and for a single cross *cv* of maize SC 647 reach to 1.367 kg m^{-3} . Stricevic *et al.* (2011) indicated that the AquaCrop model showed a good performance for simulation of the measured CWP and $ICWP$ of maize, sugar beet and sunflower; where the AquaCrop model could predict or simulate the values of crop water productivity with high degree of accuracy and modest deviation.

There were a lot of researches which described the influence of irrigation water source and management on CWP and $ICWP$ such as (Oktemet *et al.*, 2003; Kang *et al.*, 2000a ;Yazaret *et al.*, 2002a).

CONCLUSIONS

- 1) It can be concluded from this study that the CWP and $ICWP$ affected by irrigation water qualities and maize genotypes.
- 2) AquaCrop Model described the well behavior of maize genotypes evaluated under Duhok governorate condition.

Recommendations:

It recommended the following points:

1. Conducting research (studies) by using AquaCrop model on other important and strategic field crops like wheat, barley.
2. Application of AquaCrop model in the simulation of yield parameters, soil water dynamics and CWP and ICWP for the genotypes that are suitable for the region conditions.
3. Application of AquaCrop under different levels of water, irrigation systems, soil properties and more saline water stresses.

REFERENCES

- Abu Sharar, T. (1976).Relation between calculating and determined sulfates different.State organization of soil and land reclamation.Technical Bulletin No. 23.
- Allen , G., Walter, A., Elliot, L., Howell, A., Itenfisu, D., Jensen, E. and Snyder, R. (2005). The ASCE standardized reference evapotranspiration equation. ASCE and American Society of Civil Engineers.
- Allison, E. (1965). Total carbon.In: C.A. Black (ed.) Method of soil analysis, part 2. Agronomy Amer. Soc.Of Agron, adison, Wis. 9:1367- 1389.
- Azizian A. and Sepaskhah, R. (2014).International Journal of Plant Production, 8(1): 107-130.
- Blake, R. and Hartge, H. (1986).Bulk density.In Black C.A. et al., (eds.), Method of soil analysis, Agron.Mono. Part 1: 363-375. 2nd Agron.Mono. Am. Soc. Agron. Madison, WI.
- Chandrasekaran, B., Annadurai, K. and Somasundaram, E. (2010).A textbook of agronomy. New Delhi: New Age International.
- Farahani, J., Izzi, G. and Oweis, Y. (2009). Parameterization and evaluation of the AquaCrop model for full and deficit irrigated cotton.Agronomy Journal, 101(3), pp.469-476.
- Fereres, E. and Soriano, A. (2006).Deficit irrigation for reducing agricultural water use.Journal of Experimental Botany, 58(2), pp.147-159.
- Gee, W. and Bauder, W. (1986), Particle-size analysis, in A Klute (ed.) Methods of Soil Analysis, Part 1. Physical and Mineralogical Methods.Agronomy Monograph No. 9 (2ed). p. 383-411. American Society of Agronomy/Soil Science Society of America, Madison, WI.
- Hesse, R. (1972). A textbook of soil chemical analysis.Chemical publishing Co. INC. New York.
- Jackson, L. (1958). Soil Chemical Analysis.Prentice Hall.Inc. London.(Cited from P. C. Jaiswal, 2003).
- Jackson, L. (1973). Soil chemical analysis. Prentice Hall of India pvt.Ltd. New Delhi.
- Kang, S., Shi, W. and Zhang, J. (2000a). An improved water-use efficiency for maize grown under regulated deficit irrigation. Field Crops Res. 67, 207–214.
- Kijne, W., Tuong, P., Bennett, J., Bouman, B. and Oweis, T. (2003).Ensuring food security via improvement in crop water productivity. In: challenge programm on water and food: background papers to the full proposal. The challenge programm on water and food consortium, Colombo, Sri Lanka.
- Kozhekov, K. and Yakovleva, N. (1977).Determination of carbonate and carbonate mineral in soil. Soviet soil Sci. 9: 620-622.
- Mansouri-Far, C., ModarresSanavy, M. and Saberali, S. (2010).Maize yield response to deficit irrigation during low-sensitive growth stages and nitrogen rate under semi-arid climatic conditions. Agric. Water Manage. 97, 12-22.
- Molden D., Oweis, T., Steduto, P., Bindraban, P., Hanjra, M. and Kijne, J. (2010). Improving agricultural water productivity: Between optimism and caution. Agricultural Water Management 97: 528–535.
- Oktem, A., Simsek, M. and Oktem, A. (2003). Deficit irrigation effects on sweet corn (*Zea mays saccharata* Sturt) with drip irrigation in a semi-arid region. I. Water yield relationship. Agric. Water Manage. 61, 63–74.
- Page, A., Miller R. and Keeney, D. (1982).Methods of soil analysis. Chemical and Microbiological properties ,part 2, 2nd edition Agronomy No.9 .ASA, Madison, Wisconsin USA.
- Raes, D, Steduto, P., Hsiao, T. and Fereres, E. (2009).AquaCrop-The FAO crop model for predicting yield response to water: II. Main algorithms and software description.Ag.Journal (in press).
- Rowell, L. (1996). Soil science .Methods and application .Reading. Univ. UK.
- Ryan, J., Estefan, G. and Rashid, A. (2001).Soil and plant analysis Laboratory Manual.ICARDA, Alippo, Syria, and NARC, Islamabad, Pakistan. (2nd Ed.): 139 -140.
- Sadras O., Grassini, P. and Steduto, P. (2010).status of water use efficiency of main crops

- , SOLAW Background Thematic Report TR07 .
FAO,Rome.
- Sepaskhah, R., and Tafteh, A. (2012).Yield and nitrogen Inaching in rapeseed field under different nitrogen rates and water saving irrigation.Agric,Water Manage. 112, 55-62.
- Smith, M. (2000).The application of climatic data for planning and management of sustainable rainfed and irrigated crop production.Agriculture and Forest Meteorology. 103, 99–108.
- Spears, T. (2003).Irrigating Efficiently to Feed the World in 2050. [online] Available: <http://www.irrigationtoolbox.com/ReferenceDocuments/TechnicalPapers/IA/2003/IA03-409.pdf> [Accessed 13 Jun. 2016].
- Standford, S. and English, L. (1949).Use of the flame photometer in rapid soil tests for K⁺ and Ca²⁺. J. Agron. 4:446-447. (Cited from P. C. Jaiswal, 2003).
- Stricevic, R., Cosic, M., Djurovic, N., Pejic, B. and Maksimovic, L. (2011).Assessment of the FAO AquaCrop model in the simulation of rainfed and supplementally irrigated maize, sugar beet and sunf lower. Agric. Water Manage. 98, 1615-1621. Doi: 10.1016/j.agwat.2011.05.011.
- Tawfeek, A. (2006). Sorghum [Sorghum bicolor (L.) Moench] response to deficit irrigation during different growth stages and its effect on root distribution.Ph.D. Thesis, College of Agriculture, University of Baghdad.(In Arabic).
- Toth, J., Prince A., Wallace, A. and Mikkelsen, D. (1948).Rapid quantitative determination of eight mineral elements in plant tissues by a systemic procedure involving use of a flame photometer. Soil Sci. 66:459-466. (Cited from P. C. Jaiswal, 2003).
- Van Hoorn, W. (1970). Quality of irrigation water, limits of use and prediction of long term effects. Irr.And Dra.Paper (7).Salinity seminar, Baghdad, FAO/ UNESCO (1973), Rome. pp 117-135.
- Wilcox, V. (1950).Electrical conductivity.Journal. Amer. Water works assoc. 42:775-776. (Cited from Jaiswal, 2003).
- Yazar, A., Sezen, S. and Gencel, B. (2002a). Drip irrigation in the Southeast Anatolia Project (GAP) area in Turkey Irrig. Drain. 51, 293–300.