

CRACKS IN CONCRETE STRUCTURES CAUSES AND TREATMENTS: A REVIEW

MAND KAMAL ASKAR*, YAMAN AL-KAMAKI, ** RAZAQ FERHADI,*** and HISHAM KHALID MAJEED****

*Highways and Bridges Engineering, Technical College of Engineering, Duhok Polytechnic University (DPU), Kurdistan Region, Iraq.

**Dept of Civil Engineering., College of Engineering, University of Duhok (UoD), Kurdistan Region, Iraq.

*** College of Engineering, The American University of Kurdistan (AUK), Kurdistan Region, Iraq.

**** Duhok Municipality, Directorate General of Municipalities, Duhok, Kurdistan Region, Iraq & Lazgin Company, Duhok, Kurdistan Region, Iraq.

(Accepted for Publication: November 27, 2023)

ABSTRACT

Cracks are the most common problem encountered in any type of building. Hence, understanding the underlying cause, implementing preventive measures during construction, and employing appropriate treatment methods are of utmost importance. A variety of structural and non-structural elements of the building begin to show fractures due to mistakes made during construction and other inevitable causes. Therefore, it is crucial to spot these cracks quickly and take preventive measures. Although cracks in concrete cannot be avoided, they can be managed by utilizing the right materials, employing proper building methods, complying with the applicable codes and standards, and following intact design criteria. Structural fractures pose a safety risk to a particular structure due to their underlying causes, which may be attributed to deficient design, subpar construction, or excessive loading. Non-structural cracks, on the other hand, are those that result from underlying causes related to moisture or thermal fluctuations, creep, elastic deformation, chemical reaction, or issues with the foundation soil, such as moving, settling, or uncontrolled vegetation. The primary cause of non-structural cracks is internally produced stress in building materials, which typically does not directly cause structural weakness. This research illustrates various types of cracks along with their causes, prevention measures, and treatment methods.

KEYWORDS: Cracks; Causes of cracking; Prevention of cracking; measurement of cracks; Concrete.

1. INTRODUCTION

Concrete cracks are the most prevalent issue in any type of concrete construction. When the stress in a building component exceeds its strength, cracks form. External forces such as live, wind, or seismic loads will generate stress in a building component, as will interior forces such as dead load, moisture changes, thermal movements, and chemical reactions. Concrete cracking can be attributed to various factors, but in the majority of cases, it is linked to concrete specifications and construction techniques, rather than external forces and pressures [1].

Cracks are classified into two categories:

Structural Cracks and Non-Structural Cracks. Structural cracks occur due to incorrect design, faulty construction practices, or overloading. These cracks can pose a significant risk to the safety and stability of the building. Non-structural cracks are mostly caused by internally induced stresses in building materials. These cracks generally do not directly compromise the structural integrity of the building. As concrete ages, cracks can become pathways for leakages and seepages, allowing moisture, oxygen, chloride, and other aggressive chemicals and gases to penetrate the concrete [2-4]. This infiltration of harmful substances can lead to significant degradation of the structure over time. Regular maintenance is essential to prevent

further damage and ensure the longevity of the construction. Cracks in a structure are often a warning sign that something is not right. They act as an early indication that the integrity of the building may be compromised. Detecting and resolving cracks at an early stage allows engineers and building owners to implement corrective actions, preventing further deterioration and ensuring the safety and longevity of the structure. Cracks could lead to carbon dioxide penetrating, reducing the stiffness, and durability, affecting the overall structural performance, affecting the appearance of a building, could cause water leakage in the building [5-7]. To effectively manage cracks and avoid potential structural failure, regular inspections, maintenance, and adherence to proper construction standards are essential. Based on their width, cracks are classified into three categories: Thin cracks (less than 1 mm in width), Medium cracks (1 mm to 2 mm in width), and Wide cracks (greater than 2 mm in width). According to IS: 456(2000), cracking is not deemed hazardous and does not significantly affect the preservation of reinforcing steel or the longevity of buildings if the surface width of a crack should not exceed 0.3 mm in members. A maximum crack width of 0.2 mm is considered acceptable in members where cracking in the tensile zone could pose hazards, especially if exposed to moisture or in contact with soil or groundwater.

Cracks in reinforced concrete buildings stand as a pervasive and complex issue within the realm of civil engineering and architecture. As these cracks form and propagate, they can lead to concerns about structural integrity, aesthetics, and serviceability. Understanding the underlying reasons behind their development, the potential consequences they entail, and the array of possible solutions becomes paramount in safeguarding the safety and longevity of these vital structures. Concrete cracks can be a major source of frustration for engineers and contractors alike; lawsuits and other unfavorable outcomes are not uncommon. Concrete cracking

will occur before structural failure in structures designed with suitable ductility. As a result, prudent property owners view cracks in concrete as a symptom of an underlying structural problem. Concrete, on the other hand, cracks for a variety of reasons, the majority of which are non-structural [8].

It is critical to comprehend the root reason to take preventative steps. Due to poor construction procedures and inevitable causes, many types of cracks begin to form on various structural and non-structural sections of the structure. As a result, early detection of such fissures and the implementation of preventive measures are critical. Though cracks in concrete cannot be completely avoided, they can be controlled by utilizing appropriate materials and building techniques, as well as addressing design factors. Structural cracks arise from inadequate design, faulty construction, or excessive loads, posing a risk to the safety of a structure. Conversely, non-structural cracks result from factors like moisture, temperature changes, elasticity changes, gradual deformation, chemical reactions, foundation soil movement, settlement, or uncontrolled plant growth. Non-structural fractures are caused mostly by internally induced stresses in building materials, which do not immediately result in structural weakness. In this paper, crack types, causes, and preventive measures are investigated, as well as crack treatment approaches [9, 10].

2. TYPES OF CRACKS

Concrete cracks in buildings can occur due to various factors and can manifest in different types and patterns. Understanding these crack types is crucial for diagnosing the underlying issues and implementing appropriate remediation strategies. Cracks can be divided into two groups; structural cracks and non-structural cracks (**Error! Reference source not found.**). Below, different types of concrete cracks are illustrated.

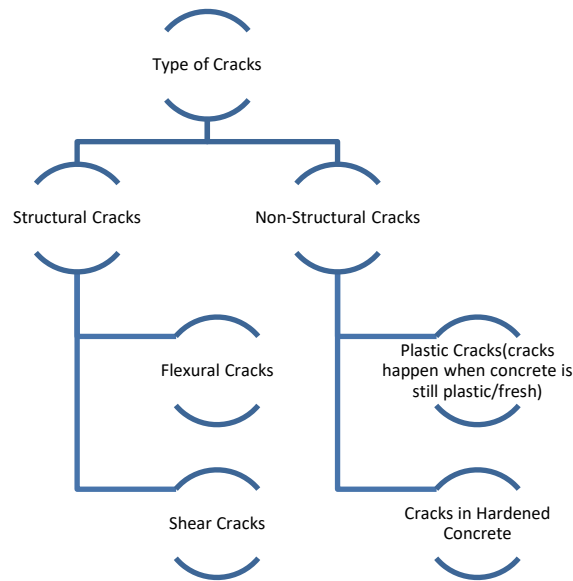

Fig.(1):- Types of cracks

2.1. Non-Structural Cracks

2.1.1 Plastic Shrinkage Cracks

These cracks typically form during the early stages of concrete curing when the surface dries out rapidly before it gains sufficient strength. They are usually shallow and random and commonly occur on large, flat surfaces like pavements and slabs. They emerge shortly after the concrete is poured, during its pliable state. These cracks enlarge as the concrete dries and contracts, often tracing the paths of the reinforcement within. They are a result of extensive bleeding and the consequent settling process. While the settling itself isn't responsible for the cracks, the typical constraint introduced by reinforcement can trigger the development of this crack type. Furthermore, this type of crack usually occurs in deep sections as concrete around the reinforcement settles but concrete

above the reinforcement can't settle which causes differential settlement, which causes this crack type, which is shown in Figure 3.1 below [11, 12].

To avoid Plastic Shrinkage Cracks:

1. Cover the concrete as soon as the finishing is complete.
2. Proper curing such as covering with plastic sheets after the concrete is placed.
3. Avoid excessive reduction of bleeding such as using silica fume in concrete.
4. Reduce the gap between the pouring of the foundation and the walls because it causes restrained cracks.
5. To reduce the temperature of hydration, retarders should be used or less amount of C3S even using LH cement if possible. Another factor is using ice which would help reduce the hydration temperature.

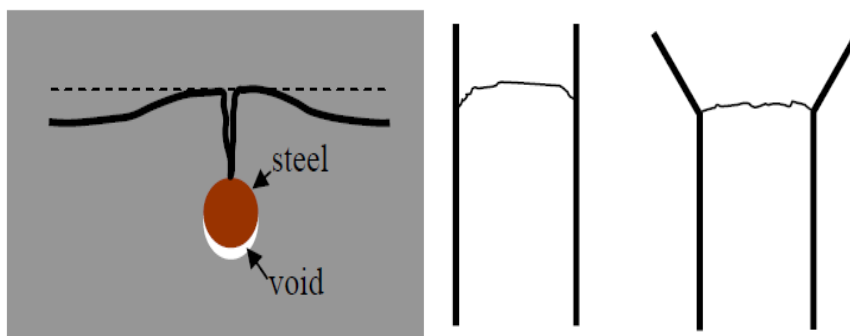

Fig.(2):- Plastic shrinkage cracks [13]

2.1.2 Plastic Settlement Cracks

Plastic settlement cracks, often referred to as "plastic shrinkage cracks," occur in freshly poured concrete as a result of rapid moisture evaporation from the surface. This phenomenon takes place during the initial stages of curing when the concrete is still in a plastic or semi-liquid state. Insufficient or uneven wetting of the surface, high ambient temperatures, low humidity, and wind contribute to the loss of moisture, causing the concrete surface to dry and shrink at a faster rate than the inner layers [14, 15]. As a consequence, these cracks appear on

the surface, typically running parallel or at slight angles to each other. While plastic settlement cracks are generally shallow and do not extend deep into the concrete, they can weaken the surface and potentially lead to more severe cracking over time if not properly addressed. Adequate curing methods, such as covering the concrete, using curing compounds, and misting with water, can help mitigate the formation of these cracks and ensure the overall durability of the concrete structure **Error! Reference source not found.**

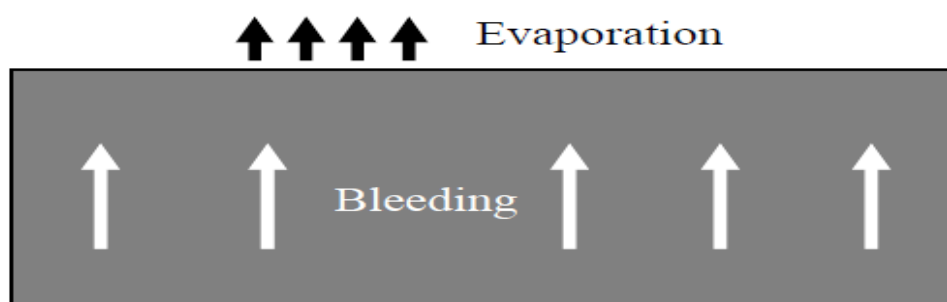

Fig.(3):- Surface moisture balance [15]

2.1.3 Thermal Cracks

Thermal cracks in concrete are cracks that occur due to temperature-related stresses and movements within the concrete structure. When concrete undergoes temperature fluctuations, it will expand or contract, leading to the development of thermal stresses. This crack type typically arises from sudden drops in temperature overnight. (**Error! Reference source not found.**). Furthermore, concrete contracts about 10 microstrains for every 1 °C, and 100 microstrains would be sufficient to cause cracking. These cracks are more likely to develop in large concrete structures such as bridges and high-rise buildings, where temperature differentials can be significant [16]. Concrete experiences temperature changes based on external factors like ambient weather conditions, solar radiation, and seasonal fluctuations. These temperature changes can cause the concrete to expand or contract. When one part of a concrete structure experiences a significantly different temperature from another part, differential expansion or contraction can occur. This is particularly common in large structures or during rapid temperature changes

[17].

Thermal conductivity: Concrete's thermal conductivity can impact its response to temperature changes. Low thermal conductivity can lead to localized heating and cooling, creating thermal gradients that induce cracking. The extent of constraint applied to the concrete during thermal expansion or contraction can impact the formation of cracks. For example, if concrete is restrained by adjacent structures or elements, it is more likely to crack [1]. Another factor that could affect thermal cracks is the composition of the concrete mix, including the type and amount of aggregates, cement, and water, which can affect its thermal properties and susceptibility to cracking.

Curing conditions: Proper curing of concrete is essential to minimize the risk of thermal cracks. Inadequate curing can lead to reduced strength and increased vulnerability to cracking [18].

There are several factors to prevent thermal cracks in concrete:

1. Joint placement: Incorporating control joints and expansion joints in the concrete structure allows for controlled cracking, relieving the

stresses caused by temperature variations.

2. Proper mix design: Ensuring an appropriate mix design that considers potential thermal stresses can help reduce the likelihood of cracking.
3. Curing: Adequate and timely curing of the concrete can help minimize temperature-related stresses and improve the overall durability of the structure.
4. Temperature control: In some cases, temperature control measures during concrete placement, such as using chilled water or insulating blankets, can help mitigate extreme temperature differentials.
5. Limiting temperature differentials: For large concrete pours, staged construction or cooling measures may be employed to avoid significant temperature differentials.

6. Avoid the use of accelerators
7. Increasing the use of retarders
8. Reducing the amount of cement.
9. Using type general purpose blended (GB) cement or low heat (LH) cement.
10. Increasing the amount of reinforcements to take up the thermal stresses.
11. Using a protective cover for concrete.

Cracks caused by temperature fluctuations are a prevalent issue in concrete, particularly in areas experiencing drastic temperature changes. Through careful attention to appropriate design, construction techniques, and effective temperature regulation strategies, it is possible to reduce the occurrence of these cracks, thereby improving the durability and strength of concrete structures.



Fig.(4):- Early thermal cracks [17]

2.1.4 Drying Shrinkage Cracks

As concrete cures and dries, it undergoes a reduction in volume due to water evaporation. Shrinkage cracks are common in walls, columns, and other confined elements, and they are characterized by vertical cracks with a tendency to appear at regular intervals. Shrinkage cracks in concrete are cracks that develop as a result of the shrinkage of the concrete during the drying process. Concrete is a mixture of cement, aggregates (such as sand and gravel), water, and sometimes admixtures. When the concrete mixture is fresh and placed, it is in a plastic and workable state. However, as the water in the mixture evaporates and the concrete hardens, it undergoes a process called drying shrinkage [19]. Drying shrinkage occurs because the water in the concrete mixture evaporates and leaves voids behind. As these voids form, the concrete volume decreases, resulting in shrinkage. The extent of shrinkage depends on various factors,

including the mix design, water-cement ratio, aggregate properties, ambient conditions, and curing methods. Drying shrinkage can exert tensile stress on the concrete, which can lead to the development of cracks. These cracks are typically small, fine cracks that may be hairline in appearance. They tend to occur near the surface of the concrete, but they can also propagate deeper into the material [12, 13].

Drying shrinkage cracks are frequently observed in concrete structures and can pose challenges if they undermine the structure's strength or visual appeal. They are more likely to occur in large, reinforced concrete elements, such as slabs, beams, and walls. The cracks can be influenced by factors such as inadequate curing, high evaporation rates, low humidity, high ambient temperatures, and improper mix design [11, 14].

To minimize drying shrinkage cracks, several measures can be taken:

1. Proper mix design: The use of suitable proportions of cement, aggregates, and water can help reduce shrinkage. Adding supplementary cementitious materials or chemical admixtures, such as shrinkage-reducing admixtures, can also be beneficial.

2. Adequate curing: Proper curing methods, such as moist curing or the use of curing compounds, help maintain the moisture in the concrete, reducing the potential for shrinkage cracks.

3. Control of drying conditions: Limiting the rate of evaporation by using windbreaks, sunshades, or wind barriers can help minimize shrinkage. Spraying water or covering the concrete with plastic sheets during curing can also be effective.

4. Joints and reinforcement: Incorporating control joints or expansion joints in the concrete structure can help accommodate the anticipated shrinkage and prevent cracks from forming in undesired locations. Reinforcing the concrete with steel bars or fibers can also help distribute the stresses and minimize crack formation.

Depending on the severity and magnitude of the cracking, drying shrinkage cracks can be repaired using a variety of methods, such as filling the cracks with appropriate sealants or

epoxy injections. It should be noted that the information provided here is based on general concrete knowledge and may not account for specific project requirements or advancements in construction materials and techniques. For specific concerns about drying shrinkage cracks in concrete, it is best to consult with a qualified structural engineer or concrete expert.

2.1.5 Long-term shrinkage cracks.

This type of crack is very common and often appears several months after initial construction. They can vary between 600 to 1000 microstrains but the creep of concrete relieves a major part of the strain. After the initial crack, the shrinkage cracks continue to widen and can be more troublesome than flexural cracks because they are wider and penetrate right through the structural member [20, 21].

2.1.6 Movement or settling of the ground cracks

This type of crack happens when the ground settles or moves and usually the shape of the cracks is vertical starting from the base to the top or 45 degrees from the corners as shown in **Error! Reference source not found.** [22, 23].



Fig.(5):- Cracking due to movement or settling of the ground [24].

2.1.7 Corrosion of steel reinforcement cracks.

Cracks due to corrosion of reinforcement are very common in concrete structures. The volume of steel increases about 8 times when it is

corroded and the extra volume will cause cracking of concrete that usually appears parallel to the steel (**Error! Reference source not found.**). In general, cracks due to corrosion take a long time to appear [25, 26].



Fig.(6):- Concrete crack due to reinforcing bar corrosion [26].

2.1.8 Sulphate attack cracks.

This type of cracks occurs when water-dissolved sulfate penetrates the concrete (**Error! Reference source not found.**). The effect of

these changes causes an overall loss of concrete strength. Furthermore, the Sulphate attack is a long-term reaction [1].



Fig.(7):- Sulphate attack cracks [1]

2.1.9 Alkali-aggregate reaction.

The Alkali-aggregate reaction refers to a reaction that happens in concrete over time between extremely alkaline cement paste and non-crystalline silicon dioxide, which is found in many common aggregates. This reaction could cause the changed aggregate to expand, resulting in spalling and concrete strength loss (Figure 8).

There are three types of alkali-aggregate reactions: alkali-silica reaction, alkali-carbonate reaction, and alkali-silicate reaction. The most prevalent reaction is the alkali-silica reaction, which is faster than the other types and affects the ductility of concrete in the early stages [1, 20].



Fig.(8):- Alkali-aggregate reaction [1]

2.1.10 Freezing and thawing cracks.

Freeze and thaw actions may occur when the

concrete is critically saturated, which leads to cracking in concrete. When approximately 91% of the pores within the concrete body are occupied by water, and in extremely cold conditions when this water transforms into ice, the expansion in volume is approximately 9%

greater compared to its original water volume. If there is no space in concrete for this extra volume, it will cause cracking after several cycles (**Error! Reference source not found.**) [18, 27].



Fig.(9):- Freezing and thawing cracks [27].

2.1.11 Autogenous Shrinkage Cracks

In young concrete, autogenous shrinkage is a significant phenomenon. At low water/cement ratios (less than about 0.42), all of the water is quickly taken into the hydration process and the demand for more water results in the formation of very thin capillaries (Figure 10). Autogenous shrinkage (also known as chemical shrinkage or

self-desiccation) occurs within capillaries and can lead to fracture. This problem can be greatly reduced by maintaining a consistently wet surface for the concrete. Standard curing treatments, such as covering the surface to prevent evaporation, are insufficient, necessitating water curing.



Fig.(10):-: Autogenous Shrinkage Cracks [28].

2.1.12 Crazeing cracks

A crazing crack refers to an intricate pattern of fine cracks on the surface of concrete, reaching a depth of approximately 0.2 mm. These cracks become apparent when the concrete surface is wet or contaminated with dirt. (**Error! Reference source not found.**)

Furthermore, crazing is caused by minor surface shrinkage in rapid drying conditions, and increased water/cement ratio while concrete is still fresh and the use of impermeable formworks such as steel or plastic. [18, 29].



Fig.(11):- Cracking crack [29].

2.1.13 Cracks caused by movement of the formwork.

If the formwork is not sufficiently sturdy, it may bow or bulge. Formwork movement can occur at any time during placement and compaction, resulting in cracks, particularly on the edges [1].

2.2 Structural Cracks.

This type of crack happens when concrete is loaded more than its capacity and causes flexural or shear cracks, therefore the load applied is normal, but the problem could be design defects and this will be discussed in Structural cracks below [30].

2.2.1 Flexural Cracks

These cracks occur due to excessive bending or tensile stresses on the concrete. They often appear in beams, slabs, and other elements subjected to heavy loads. Flexural cracks are typically diagonal or slightly curved and form near the midpoint of the span (**Error! Reference source not found.**). These cracks typically develop on the tension side of the member where the concrete is under tensile stress. Since concrete is stronger in compression than in tension, it tends to crack when subjected to tensile forces [31, 32]. Flexural cracks can result from various factors, including excessive loads, inadequate design, poor reinforcement, improper construction practices, or temperature and

shrinkage effects. In the case of beams, they tend to appear on the tensile face near the midpoint of the span. The width of flexural cracks can vary, ranging from very narrow hairline cracks to wider openings, depending on the magnitude of the applied loads and the properties of the concrete. The pattern of flexural cracks is generally diagonal to the longitudinal axis of the member and perpendicular to the direction of applied loads [33].

While flexural cracks can affect the appearance of the concrete surface and potentially lead to water penetration, they may not necessarily compromise the structural integrity of the member if they are controlled and within acceptable limits. Repairing flexural cracks typically involves injecting epoxy resins or other suitable materials to fill the cracks and restore the structural integrity. Preventive measures encompass proper design, sufficient reinforcement, and meticulous focus on curing and shrinkage management throughout the construction process. It's important to note that the presence of flexural cracks doesn't necessarily indicate a failure in the concrete member; it's a natural response to applied loads and the behavior of concrete under tensile stress. However, understanding and addressing these cracks promptly can extend the service life and durability of the concrete structure.

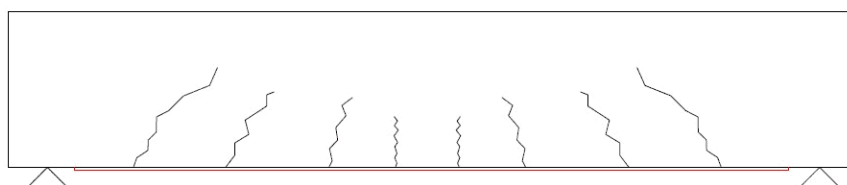

Fig.(12):- Flexural crack failure [34].

2.2.2 Shear Cracks

Shear cracks develop when the concrete's shear capacity is exceeded, usually near the supports of beams and slabs. They appear as

diagonal cracks and may indicate inadequate reinforcement or design issues. Shear cracks in concrete typically appear diagonally across a structural member, such as a beam or a slab

(**Error! Reference source not found.**). They are generally inclined at approximately 45 degrees to the axis of the member. Shear cracks can also occur in other structural elements like columns and walls, but they are most commonly observed in beams and slabs [35, 36]. Several causes of Shear Cracks in concrete are listed below:

- **Insufficient Reinforcement:** One of the primary reasons for shear cracks is the lack of proper reinforcement. Reinforcement, such as steel bars, helps to strengthen the concrete and improves its resistance to shear forces.
- **High Shear Load:** Excessive loads or sudden concentrated loads on a concrete member can cause shear cracks to form.
- **Poor Quality Concrete:** If the concrete used in construction is of low quality, it may not be able to withstand the applied shear forces.
- **Improper Design:** Inadequate or improper structural design can lead to weak sections in the concrete, making it susceptible to shear failures.
- **Inadequate Construction Joints:** Construction joints, if not properly designed and placed, can

create weak points where shear cracks may develop.

- **Settlement or Shifting of the Foundation:** Uneven settlement or shifting of the foundation can cause shear forces in the structure, leading to shear cracks.

Shear cracks in concrete should be taken seriously as they can compromise the structural integrity of the building or infrastructure. Shear failure occurs when the concrete's ability to resist horizontal forces is compromised, often resulting in the structure suddenly giving way. This can be particularly hazardous as it may lead to a collapse of the structure, especially in cases where the shear capacity is significantly exceeded. Regular inspections, proper design, and adequate reinforcement can help minimize the risk of shear cracks. If shear cracks are detected, consulting a qualified structural engineer to assess the severity and recommend appropriate repairs is essential to ensure the safety and longevity of the structure.

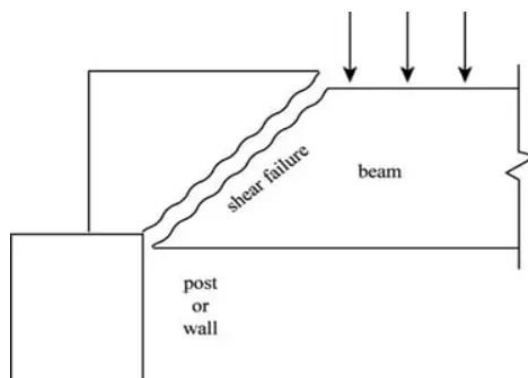

Fig.(13):- Shear crack [37].

2.2.3 Overloading or Impact Cracks

Excessive loads or impacts on concrete elements can result in localized cracks, which may be visible on the surface. It is essential to identify the specific type of crack to determine the appropriate repair or mitigation measures. Regular inspection and early intervention can help prevent further damage and ensure the long-term durability and safety of concrete buildings [28].

2.2.4 Torsional Forces Cracks

Cracks caused by torsion in buildings are a common structural issue that can have significant consequences if not properly addressed. Torsion refers to the twisting or rotational force applied to a building's structural elements, typically arising from various sources

such as wind loads, seismic activity, or uneven settlement of the foundation. These forces can lead to the development of cracks in the building's walls, floors, and other structural components [38, 39].

Torsion occurs when a force acts on a building's structure in a way that induces rotational movement. Unlike axial forces (compression or tension) that act along the length of a structural element, torsional forces cause twisting Fig.(14):- Torsional crack. This twisting effect can be particularly damaging because it places uneven stresses on different parts of the building causing torsion cracks. The cracks could be often manifest as diagonal cracks in walls, especially at the corners of buildings or near openings such as doors and

windows. These cracks may appear as zigzag patterns and are typically wider at the top than at the bottom [38, 40].

In order to prevent or reduce torsion cracks, in cases where torsional cracking has already occurred, reinforcement measures may be necessary. This could involve adding additional

structural elements or strengthening existing ones. Another good practice would be a proper building design, including symmetric layouts and the use of structural elements like shear walls, can help distribute torsional forces more evenly [41].

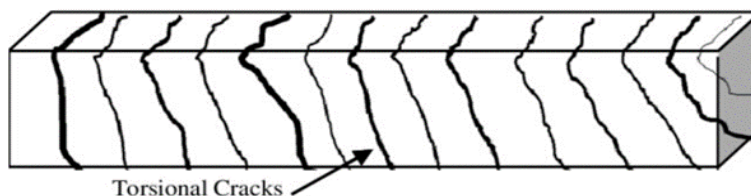

Fig.(14):- Torsional crack

3 Classify cracks based on crack width

In general, crack width is controlled within the design phase of any project and the width of cracks depends on the type of construction. A crack becomes visually discernible when its width reaches or exceeds 0.2 mm. For instance, in the case of a tall architectural edifice, cracks

narrower than 0.2 mm are imperative, whereas a standard building might typically accommodate a crack width of around 0.3 mm. (Table(1)). In some construction such as tunnels, cracks should be controlled to prevent water from coming inside the tunnel.

Table(1):- Crack classification based on width

Crack classification	Crack width
Thin	less than 1 mm
Medium	1 to 2 mm
Wide	more than 2 mm

4. Prevention of Cracks in Buildings

Preventing cracks in buildings is essential to maintain their structural integrity and durability. The following strategies can be employed to minimize the occurrence of cracks [42]:

4.1 Robust Design and Construction:

- Conduct comprehensive structural analysis and testing before construction.
- Implement quality material selection and maintain construction standards.
- Properly designed and executed foundation systems.
- Incorporate expansion joints to accommodate material movements.

4.2 Site Analysis and Preparation:

- Conduct thorough site investigations to identify potential geological issues.
- Properly compact and stabilize the foundation soil to prevent uneven settlement.

4.3 Material Selection and Testing:

- Choose durable materials appropriate for the building's intended use and location.
- Test materials for structural integrity, thermal

expansion, and chemical resistance.

4.4 Structural Reinforcement:

- Use reinforcement materials like steel bars in concrete to increase tensile strength.
- Strengthen vulnerable areas prone to high-stress concentrations.
- Regular Maintenance and Inspection:
 - Establish a maintenance plan to monitor and address potential issues promptly.
 - Regularly inspect the building's structural elements to detect cracks early.

4.5 Environmental Protections:

- Implement measures to protect against chemical and environmental degradation.
- Use materials resistant to specific environmental factors when applicable.

4.6 Joints:

- Remove as many external restrictions as possible, especially by including mobility joints where practical.
- Control joints are pre-determined weak areas that are intentionally designed to cause shrinkage or thermal cracks.

4.7 Concrete:

- Use concrete with a moderate slump of up to 5 inches.

- Water-reducing admixtures can be used.

However, using silica fume is not recommended due to its effect on plastic shrinkage.

- The mix should be tested and balanced to satisfy the factors which caused the cracks.

4.8 Placement and curing:

- Cure exposed surfaces thoroughly and promptly, especially big flat areas.

- Rapid water loss and significant temperature changes should be avoided as much as possible while the concrete is curing.

- If forms are removed sooner than 7 days, some further curing on the wall should be applied immediately after form removals, such as water fog/spray, plastic sheets, wet burlap, or curing compound.

4.9 By Construction:

- Improper compaction: This may be the reason for the appearance of cracks.

- Lack of curing after pouring

5. Techniques to cure cracks/ treatment

Resolving concrete cracks depends on the severity and cause of the cracks. Here are some general steps to address common concrete cracks whether the cracks are structural cracks or construction cracks [17, 18, 21, 43]:

- Identify the crack type: There are various types of cracks in concrete, including shrinkage cracks, settlement cracks, structural cracks, and more. Identifying the type of crack will help determine the appropriate repair method.

- Clean the crack: Use a wire brush or other suitable tools to remove any loose debris, dirt, or vegetation from the crack. A clean surface ensures better adhesion for the repair material.

- Inject epoxy or polyurethane: For narrow cracks, consider using epoxy or polyurethane

injection. These materials penetrate deep into the crack, effectively sealing it and preventing water infiltration. This method works well for hairline cracks or cracks up to about 0.25 inches wide.

- Patch with concrete repair mix: For larger cracks, you can use a concrete repair mix. Mix the repair material according to the manufacturer's instructions and fill the crack. Smooth the surface with a trowel or a putty knife. This method is suitable for cracks wider than 0.25 inches.

- Seal the surface: Once the crack has been repaired, it's a good idea to apply a concrete sealer to protect the surface from moisture and other elements, which can potentially cause more cracks in the future.

- Address the underlying cause: Simply repairing the cracks may not be enough if there's an underlying issue causing the cracking, such as poor sub-base, improper mix design, or heavy loads. Addressing the root cause will help prevent future cracks from forming.

- Preventative measures: Regular maintenance, such as sealing the concrete every few years and keeping the surface clean and free from debris, can help extend the life of the concrete and minimize the risk of future cracks.

5.1 Epoxy injection methods

Epoxy injection is an effective method for repairing concrete cracks, especially narrow cracks and those that need to be structurally restored. It involves injecting epoxy resin into the cracks to bond and seal them. Here's a step-by-step guide on how to perform epoxy injection for concrete cracks:

5.2 Drilling and plugging

Drilling and plugging a crack entails drilling down the crack's length and grouting it to produce a key. This technique is commonly used to fix vertical gaps in retaining walls [Figure 15].

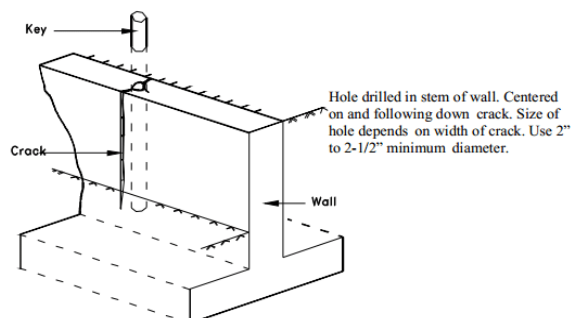

Fig.(15):- Drilling and plugging technique [44].

5.3 Epoxy injection

The injection of epoxy can bond fissures as small as 0.002 inches (0.05 mm), as seen in Figure 16. After that, the crack on exposed surfaces is sealed, and epoxy is injected under

pressure. Although the underlying cause of the cracking has been resolved, it will likely return close to the initial crack [11, 30].

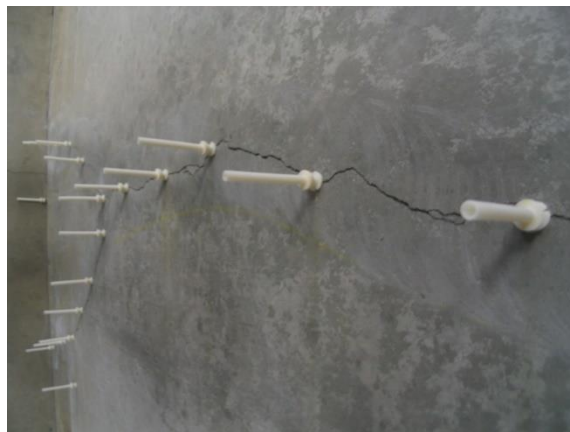

Fig.(1):- Epoxy injection [45].

5.4 Routing and sealing

This technique entails expanding the fractures along its exposed face, filling them in, and sealing them with an appropriate joint sealer as seen in Figure 17. The method works best on

roughly horizontal, flat surfaces like floors and pavements. On curved surfaces, including pipes, piles, and poles, routing and sealing can be done [31].

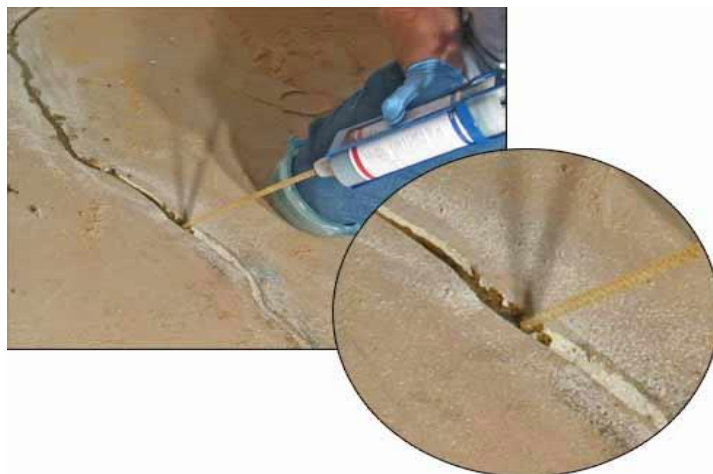

Fig.(2):- Crack routing and sealing [46].

5.5 Repairing structural concrete cracks

Repairing structural concrete cracks requires a more thorough approach than cosmetic crack repairs. Structural cracks can compromise the integrity of the concrete, so it's essential to take the necessary steps to restore the strength and durability of the structure [19, 47-50]. Below is a general guide for repairing structural concrete cracks:

1. Assessment and Safety:

Before starting any repairs, assess the extent

and severity of the cracks. It's crucial to identify the underlying cause of the cracks to prevent them from recurring.

Ensure safety measures are in place. If the structural stability is compromised, consider shoring or bracing the affected area before starting repairs.

2. Surface Preparation:

Clean the crack and the surrounding area thoroughly to remove dirt, loose concrete, and contaminants. Use a wire brush, pressure

washer, or appropriate tools to achieve a clean and sound substrate.

3. Routing the Crack:

For structural crack repairs, it's often necessary to widen the crack along its length to create a suitable space for the repair material to bond effectively. This process is known as "routing" or "grooving" the crack.

Use a diamond-blade crack chaser or a grinder to create a V-shaped groove along the crack.

4. Bonding Agent:

Apply a bonding agent to the cleaned and routed crack. The bonding agent improves the adhesion of the repair material to the existing concrete.

5. Epoxy or Polyurethane Injection:

For narrow cracks, epoxy or polyurethane injection can be used to restore the structural integrity. The injection process involves filling the crack with epoxy or polyurethane to bond and seal it. This method is effective for cracks

that are actively moving or subject to stress.

6. Concrete Repair Mortar:

For wider cracks or areas with missing concrete, use a high-quality, structural repair mortar. Prepare the repair mortar according to the manufacturer's instructions and fill the routed crack with the mortar using appropriate tools.

7. Concrete crack reinforcement:

For particularly wide or severe cracks, consider using reinforcement materials like carbon fiber strips or steel plates to enhance the repair's strength.

- **Steel Reinforcement:** The most common method is the use of steel reinforcement bars (rebar) placed within the concrete. Rebar provides tensile strength to the concrete, preventing the formation of wide cracks and holding the concrete together even if cracks do occur **Error! Reference source not found.**



Fig.(3):- Mesh steel reinforcement [18].

- **Fiber Reinforcement:** Adding fibers to the concrete mix can improve its ductility and control crack formation. Fibers, such as steel fibers or synthetic fibers, create a three-dimensional reinforcement that can help prevent crack propagation.

- **Crack Control Joints:** These are intentional, pre-planned lines or grooves in the concrete that control the location and direction of cracks. By creating weakened planes along specific lines, crack control joints encourage cracks to form in predetermined locations, minimizing their impact on the overall structure.

- **Carbon Fiber Reinforcement:** Carbon fiber sheets or strips can be applied to the surface of existing concrete to strengthen and stabilize it. Carbon fiber reinforcement is particularly useful for repairing and strengthening cracked concrete elements.
- **Epoxy Injection:** Epoxy resin can be injected into cracks to fill and bond them, restoring the integrity of the concrete. This technique is often used for repairing narrow cracks in concrete structures.
- **External Post-Tensioning:** For larger structures or slabs, external post-tensioning tendons can be installed on the concrete surface to provide additional reinforcement and distribute stresses, reducing the likelihood of cracks.
- **Polymer-Based Systems:** Polymer-based materials, such as polymer-modified mortars or coatings, can be used to repair and strengthen concrete cracks and prevent further crack propagation.

8. Curing and Protection:

After completing the repair, follow the curing requirements specified by the repair material manufacturer. Proper curing is essential for the repair material to achieve its full strength. Protect the repaired area from traffic or other loads during the curing period.

9. Address Underlying Issues:

Identify and address the root cause of the cracks to prevent their recurrence. It could be due to structural design issues, excessive loads, settlement, or other factors.

5.6 Using CFRP as recent technology for repairing structural concrete cracks

CFRP (Carbon Fiber Reinforced Polymer) is an effective material for preventing and controlling cracks in concrete structures. CFRP offers high tensile strength and excellent bonding properties, making it an ideal choice for crack prevention and repair Fig.(4). Here are some ways CFRP can be used for concrete crack prevention:



Fig.(4):- Repairing cracks using CFRP composite [51].

- **Externally Bonded CFRP Strips:** CFRP strips can be externally bonded to the surface of the concrete element, such as beams, columns, and slabs. These strips provide additional tensile strength to the concrete, enhancing its resistance to cracking and improving its overall load-carrying capacity.
- **CFRP Sheets or Fabrics:** Large areas of concrete surfaces with a potential for cracking can be reinforced with CFRP sheets or fabrics. The CFRP material is applied to the concrete surface using epoxy adhesives, forming a continuous reinforcement layer that helps distribute loads and control crack widths.
- **Strengthening Weak Zones:** In areas where the concrete is prone to cracking, such as near-stress concentration points or joints, CFRP

reinforcement can be used to strengthen these weak zones and minimize the likelihood of cracks forming.

- **Structural Retrofitting:** For existing concrete structures with visible cracks or signs of distress, CFRP can be used for structural retrofitting. CFRP laminates can be applied to strengthen and restore the integrity of the concrete elements, preventing further crack propagation.

- **Shear Reinforcement:** CFRP can also be used to provide shear reinforcement for concrete members, enhancing their resistance to shear forces and reducing the potential for diagonal cracking.

- **Flexural Strengthening:** By applying CFRP strips or fabrics to the tension side of concrete beams and slabs, their flexural capacity can be

significantly enhanced, reducing the risk of flexural cracking.

- **Prestressed CFRP Systems:** Prestressed CFRP systems can be used to apply a compressive force to the concrete, counteracting the tensile stresses that lead to cracking. This technique is particularly useful for preventing early-age cracking in concrete.

Benefits of CFRP for Concrete Crack Prevention:

- **High strength-to-weight ratio:** CFRP is lightweight but provides exceptional tensile strength, making it highly effective for crack prevention without adding significant weight to the structure.
- **Corrosion-resistant:** CFRP does not corrode like traditional steel reinforcement, ensuring long-term durability and performance.
- **Flexibility:** CFRP materials can be tailored and applied in various configurations to suit different concrete crack prevention needs.
- **Rapid installation:** CFRP systems can be installed relatively quickly, minimizing construction downtime.

CFRP composite, however, it's essential to engage qualified engineers and professionals experienced in CFRP applications to ensure proper design, installation, and quality control. Proper surface preparation and adhesion between CFRP and concrete are critical for the effectiveness of CFRP reinforcement in preventing concrete cracks.

6. CONCLUSION

Cracks in buildings can pose significant risks to structural integrity, safety, and aesthetics. Understanding the various causes, from poor construction practices to environmental influences and natural events, is essential in developing effective preventive measures. By adopting proper design practices, utilizing high-quality materials, conducting thorough soil assessments, and implementing regular maintenance, we can minimize the occurrence of cracks and ensure the durability and safety of our buildings. Collaboration between architects, engineers, contractors, and building owners is crucial in creating a built environment that withstands the challenges of time and environmental forces. Additionally, adherence to building codes and regulations and the adoption of innovative technologies contribute to constructing more resilient and crack-resistant

structures.

Cracks in buildings can result from a numerous causes, but with proper preventive measures, their occurrence can be significantly reduced. Effective design, construction, and maintenance strategies are vital to ensuring the longevity and safety of buildings, protecting both the investment and the lives of the occupants. By understanding the causes and implementing preventive measures, we can build a more sustainable and resilient future for our infrastructure.

- **Cracks due to plastic settlement** Cracks usually occur when we have a large area of concrete exposed to the environment such as a large slab.
- **Thermal Contraction Cracks due to the Temperature Drop of Fresh Concrete.** Thermal Contraction of Concrete occurs due to overnight temperature drops and can add to an evaporation reaction which can lead the plastic shrinkage and cause this type of crack. Concrete contracts about 10 micro strains for every 1 degree Celsius. Resulting in about 100 micro strains can be sufficient to cause cracking.
- Besides, the bad quality in construction involving inadequate or lack of curing concrete after pouring could be a factor behind causing this type of cracks.
- If drying shrinkage cracks do occur, they can be repaired using various methods, such as filling the cracks with suitable sealants or epoxy injections, depending on the severity and extent of the cracking. It's important to note that the information provided here is based on general knowledge of concrete and may not account for specific project requirements or advancements in construction materials and techniques. Consulting with a qualified structural engineer or concrete expert is recommended for addressing specific concerns related to drying shrinkage cracks in concrete.
- The use of steel reinforcement bars (rebar) is one of the most common methods to prevent cracking in concrete. Rebar provides additional tensile strength, which helps the concrete withstand tensile stresses and minimize crack widths.
- Adding fibers to the concrete mix can improve its tensile strength and reduce cracking. Steel fibers or synthetic fibers dispersed throughout the concrete create a three-dimensional reinforcement network that can effectively control crack propagation.

- For preventing and handling cracks in concrete structures, CFRP is a useful material. CFRP is a great option for crack prevention and repair because of its high tensile strength and excellent bonding qualities.

REFERENCES

- Narwaria, R.S. and A. Tiwari, Development of cracks in concrete, preventive measures and treatment methods: A review. *International Research Journal of Engineering and Technology*, 2016. 3(9): p. 671-677.
- Bažant, Z., Mechanics of fracture and progressive cracking in concrete structures, in *Fracture mechanics of concrete: Structural application and numerical calculation*. 1985, Springer. p. 1-94.
- Leonhardt, F., Cracks and crack control in concrete structures. *Pci Journal*, 1988. 33(4): p. 124-145.
- Velumani, P., et al. Analysis of cracks in structures and buildings. in *Journal of Physics: Conference Series*. 2020. IOP Publishing.
- Roberts, C., Evaluating cracks in Buildings. C. Roberts Consulting Engineers Inc., Rochelle, <http://www.croberts.com>, 2012: p. 56.
- Rama, J.K., et al., Study of cracks in buildings. 2009, PhD Thesis.
- Thagunna, G. Building cracks—causes and remedies. in *3rd World Conference on Applied Sciences, Engineering & Technology at Basha Research Centre*. 2014.
- Pise, N., et al., A brief study on causes of cracks, prevention and pattern of cracks on concrete. *Int. J. Sci. Res. Sci. Eng. Technol*, 2021. 8(3): p. 439-443.
- Matar, A.M.A., Methods of treating and restoration of building cracks. *Aim & Scope*: p. 11.
- Safiuddin, M., et al., Early-age cracking in concrete: Causes, consequences, remedial measures, and recommendations. *Applied Sciences*, 2018. 8(10): p. 1730.
- Bertelsen, I., L. Ottosen, and G. Fischer, Influence of fibre characteristics on plastic shrinkage cracking in cement-based materials: A review. *Construction and Building Materials*, 2020. 230: p. 116769.
- Ghoddousi, P., et al., Prediction of plastic shrinkage cracking of self-compacting concrete. *Advances in Civil Engineering*, 2019. 2019: p. 1-7.
- Sayahi, F., Plastic shrinkage cracking in concrete: Mitigation and modelling. 2019, Luleå University of Technology.
- Zhao, H., et al., Effect of clay content on plastic shrinkage cracking of cementitious materials. *Construction and Building Materials*, 2022. 342: p. 127989.
- Kayondo, M., R. Combrinck, and W. Boshoff, State-of-the-art review on plastic cracking of concrete. *Construction and Building Materials*, 2019. 225: p. 886-899.
- Zhang, Y., et al., Simulation of thermal stress and control measures for rock-filled concrete dam in high-altitude and cold regions. *Engineering Structures*, 2021. 230: p. 111721.
- Doshi, S., et al., Methodology for prevention and repair of cracks in building. *GRD Journals-Global Research and Development Journal for Engineering*, 2018. 3(3): p. 52-57.
- More, S. and T. Hirlekar, a Review on Causes, Prevention, Repair and Maintenance of Cracks in Building (Residential and Commercial). *International Research Journal of Engineering and Technology (IRJET)*, 2017. 4(11): p. 1339-1342.
- Azarhomayun, F., et al., Effect of calcium stearate and aluminum powder on free and restrained drying shrinkage, crack characteristic and mechanical properties of concrete. *Cement and Concrete Composites*, 2022. 125: p. 104276.
- Moelich, G.M., J. Kruger, and R. Combrinck, Plastic shrinkage cracking in 3D printed concrete. *Composites Part B: Engineering*, 2020. 200: p. 108313.
- Soni, A.N., Crack Detection in buildings using convolutional neural Network. *Journal for Innovative Development in Pharmaceutical and Technical Science*, 2019. 2(6): p. 54-59.
- Verma, A., D. Yadav, and K. Tiwari, STUDY, PREVENTION AND REPAIR OF CRACKS IN BUILDING. *International Journal of Engineering, Management & Technology*, 2022: p. 104-110.
- Yunusa, G.H., et al., Geotechnical investigation into the causes of cracks in building: A case study. *Electronic Journal of Geotechnical Engineering*, 2013. 18: p. 2823-2833.
- Ou, C.-Y., F. Teng, and C.-W. Li, A simplified estimation of excavation-induced ground movements for adjacent building damage potential assessment. *Tunnelling and Underground Space Technology*, 2020. 106: p. 103561.
- Hay, R. and C.P. Ostertag, Influence of transverse cracks and interfacial damage on corrosion of steel in concrete with and without fiber hybridization. *Corrosion Science*, 2019. 153: p. 213-224.
- Sola, E., et al., Experimental and numerical study of accelerated corrosion of steel reinforcement in concrete: Transport of corrosion products. *Cement and Concrete Research*, 2019. 120: p. 119-131.
- Tang, X., et al., The propagation and interaction of cracks under freeze-thaw cycling in rock-like material. *International Journal of Rock Mechanics and Mining Sciences*, 2022. 154: p. 105112.

- Chitte, C.J. and Y.N. Sonawane, Study on causes and prevention of cracks in building. *Int. J. Res. Appl. Sci. Eng. Technol*, 2018. 6(3): p. 453-461.
- Palmer, B., SLAB AND FLOORS CRACKS AND CRAZING, IDENTIFIED THERE TYPES AND WAY TO REPAIR.
- Bonshor, R.B., L.L. Bonshor, and R. Sadgrove, *Cracking in buildings*. 1996: Construction Research Communications Limited London, UK.
- Askar, M.K., A.F. Hassan, and Y.S.S. Al-Kamaki, Flexural and shear strengthening of reinforced concrete beams using FRP composites: A state of the art. *Case Studies in Construction Materials*, 2022: p. e01189.
- Askar, M., K. Abduka, and L. Askar, Seismic Vulnerability Assessment of Reinforced Concrete Structures in Kurdistan Region-Iraq. *Journal of Duhok University*, 2020. 23(2): p. 116-130.
- Borosnyói, A. and G.L. Balázs, Models for flexural cracking in concrete: the state of the art. *Structural Concrete*, 2005. 6(2): p. 53-62.
- Ahmed, H.Q., D.K. Jaf, and S.A. Yaseen, Flexural strength and failure of geopolymer concrete beams reinforced with carbon fibre-reinforced polymer bars. *Construction and Building Materials*, 2020. 231: p. 117185.
- Fu, Y., et al., Investigating the failure behaviors of RC beams without stirrups under impact loading. *International Journal of Impact Engineering*, 2020. 137: p. 103432.
- Malm, R., Shear cracks in concrete structures subjected to in-plane stresses. 2006, KTH.
- Jumaa, G.B. and A.R. Yousif, Size effect on the shear failure of high-strength concrete beams reinforced with basalt FRP bars and stirrups. *Construction and Building Materials*, 2019. 209: p. 77-94.
- Dem'Yanov, A., The modeling method of discrete cracks in reinforced concrete under the torsion with bending. *Magazine of Civil Engineering*, 2018(5 (81)): p. 160-173.
- Ghobarah, A., M. Ghorbel, and S. Chidiac, Upgrading torsional resistance of reinforced concrete beams using fiber-reinforced polymer. *Journal of composites for construction*, 2002. 6(4): p. 257-263.
- Hsu, T.T.C., *Torsion of reinforced concrete*. 1984.
- Kolchunov, V., et al. Calculation of the stiffness of reinforced concrete structures under the action of torsion and bending. in *Journal of Physics: Conference Series*. 2019. IOP Publishing.
- Nguyen, T.-C., T.-P. Huynh, and V.-L. Tang, Prevention of crack formation in massive concrete at an early age by cooling pipe system. *Asian Journal of Civil Engineering*, 2019. 20: p. 1101-1107.
- Askar, M.K., Y.S.S. Al-Kamaki, and A. Hassan, Utilizing Polyethylene Terephthalate PET in Concrete: A Review. *Polymers*, 2023. 15(15): p. 3320.
- Aruya, G.A. and V.K. Chukwuemezie, Causes of Cracks on Concrete Structures and Repair Methods.
- Abdulqadir, Z.M. and F.R. Karim, Evaluating the Efficiency of Epoxy Injection Technique for Repairing Normal and High Strength Concrete Beams-A Critical Review. *CONSTRUCTION*, 2022. 2(2): p. 48-55.
- Fan, W., et al., Repair effect of cracked reinforced concrete based on electrochemical rehabilitation technology. *Journal of Building Engineering*, 2022. 61: p. 105211.
- Askar, M.K., et al., Effects of chopped CFRP fiber on mechanical properties of concrete. *Heliyon*, 2023. 9(3): p. e13832.
- Askar, M.K., M.H. Selman, and S.I. Mohammed, Mechanical Properties of Concrete Reinforced with Alternative Fibers. *Journal of Duhok University*, 2020. 23(1): p. 149-158.
- Askar, L.K., I.H.M. Albarwary, and M.K. Askar, Use of Expanded Polystyrene (EPS) Beads in Silica-Fume Concrete. *Journal of Duhok University*, 2019. 22(1): p. 30-38.
- Golewski, G.L., The phenomenon of cracking in cement concretes and reinforced concrete structures: the mechanism of cracks formation, causes of their initiation, types and places of occurrence, and methods of detection—a review. *Buildings*, 2023. 13(3): p. 765.
- Frhaan, W.K.M., et al., CFRP for strengthening and repairing reinforced concrete: a review. *Innovative Infrastructure Solutions*, 2021. 6: p. 1-13.