

DESIGN AND ANALYSIS A BROADBAND PRINTED-DIPOLE ANTENNA FOR 4G/5G MOBILE SMARTPHONE

ABEER KAMIL HACHIM*, MOHAMMED ABOUD KADHIM**, and HAMOOD SHEHAB HAMID*

* Electrical and Electronic Technology college - Middle Technical University- Iraq

** Institute of Technology Baghdad - Middle Technical University -Iraq

(Accepted for Publication: November 27, 2023)

ABSTRACT

Wireless communications are of great importance in our lives, especially mobile phones, and based on this importance, we propose in this research an antenna . It works on the medium frequencies of both 4G/5G technologies . The proposed antenna has dimension (17.7×7) mm (length x width) made of copper and a substrate FR-4 the finished thickness is 1.67mm .This design is connected in the port it equals 1mm by using microstrip line method . The ground and substrate layers are a symmetrical rectangle. The patch is also simple, as it represents a strip of copper that surrounds the rectangle on three sides. It has only one line in the middle with a length of 8.5mm and a width of 1mm. The design is simple as it does not have any openings. Small size and small thickness makes it suitable for the size of modern mobiles. The micorstrio patch antenna is was designed by using CST studio -2019 and manufactured via the ProtoMat-100 machine. The antenna operates at range frequencies (2.35-3.74) GHz and .It has resonance frequency 2.9 GHz at return loss of -54 dB.

KEYWORDS: Broadband; Printed; Antenna; 4G/5G; Mobile

1. INTRODUCTION

The introduction of 4G marked the beginning of the era of the smartphone and portable multipurpose device. In order to achieve potential download rates of 10mbps to 1gbps, The first generation to use Long-Term Evolution (LTE) technology is 4G. As a result, end users benefit from lower inactivity, the sound quality is improved, real-time social networking, high quality data streaming, and faster download [9]. With this invention, applications such remote broadband access , chat of video and others will be fit to arraign with a Quality Of Service (QOS) [3]. The initial IP-based mobile network, 4G, offers telephony

as a logical extra feature. With the rapid development of fourth-generation (4G) mobile communication advances, portable phone radio wires have grown increasingly interesting due to the numerous applications available in such frameworks [1]. In actuality, the antennas, which are an essential aspect of portable terminals, have an impact on the entire operation of these communication frameworks. remote communication of 4G is needed in medband and broadband applications, the standard mobile phone antennas have been found to be scanty [5]. A significant focus of recent communication business research has been on various tiny long term advancement (LTE) adaptable phone receiving cables [11]. To understand the

problems with coordinating radio waves in 4G portable phones, to improve the execution of receiving waves within the LTE groups, several approaches have been attempted. [16]. These alternate plans, on the other hand, frequently call for enormous volume, which may not be compatible with the modern mobile environment.

The portable industry is highly excited about the impending 5G network. According to some researchers, the network will alter how we access the internet and how we utilize our gadgets, including our phones. The network's increased capacity as well as speed will usher in unexplored IOT trends like smart cities , connected cars, and workplace[15]. The yearning standard is created to satisfy the requirements of the aforementioned developing applications and offers a significant performance improvement over 4G. Latency of 1-msec (VS. 30msec -50msec for 4-generatoe) will allow for almost real-time reaction rates, association densities of 1000 devices per square kilometer (100 times higher than 4G), and throughputs of up to 10Gbps (100 times faster than 4G systems) are anticipated to meet the growing demand for transmission capacity[4]. The time of 5G has

come. The promise of a faster, highdata rate network and reduced idleness for real-time attachment entices customers. This will enable previously untapped video formats like(360 degree) video, as well as contemporary innovations such as expanded or virtual reality involvement, autonomous driving, and a material web with applications ranging of transportation frameworks and manufacture computerization to healthcare, education, and more[6]. Designing radio cables to support the current 5G recurrence groups will raise the bar considerably higher than engineers have ever found when designing reception lines for flexible phones. Recurrence extend 2 for communication at millimeter wave frequencies over 24GHz and recurrence extend 1 for communication in the sub-6 GHz groups are the two most fascinating recurrence ranges[8].

The antenna in this paper improves the work of the mobile phone on both 4G/5G technologies, as the frequencies that operate It has 4G and 5G frequencies and merges them together so that one antenna (one design) works within the aforementioned (LTE) and (NR) technology together, as it works on frequencies from[1GHz-6GHz], which is called (sub band) as shown in the figure below:

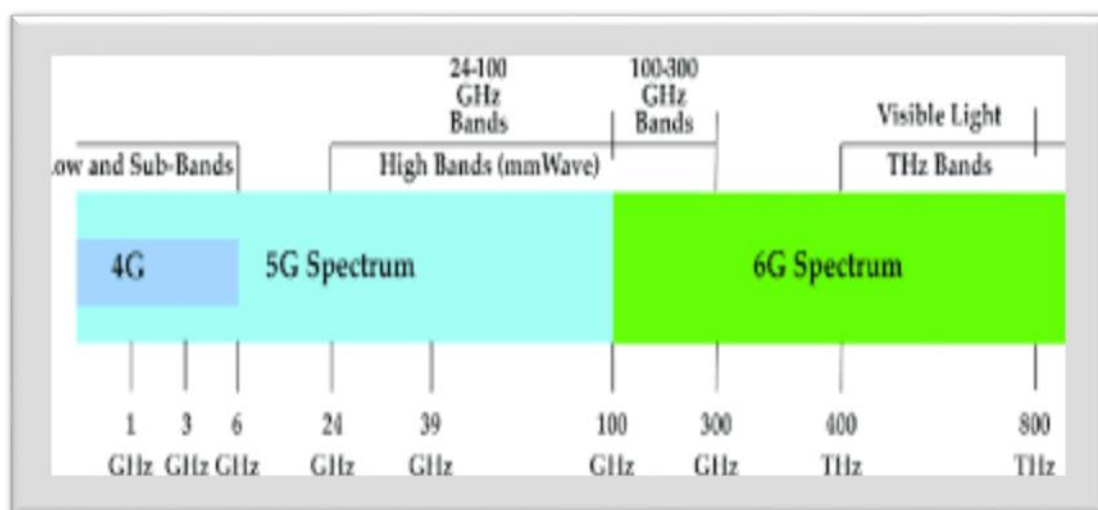
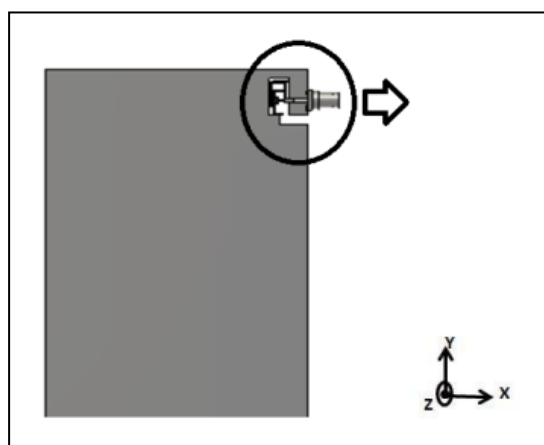

Fig.(1):-the range of frequencies in 4G/5G [2]

2. THE PROPOSED ANTENNA CONFIGURATION

Figure 3 displays specifications as well as measurements of suggested antenna. The (FR4) substrate, which forms the foundation of the (SCB) System Circuit Board, possesses the following traits :Length=17.7mm, width= 7mm and conductor layers in both the top and bottom layers are(copper) are 0.035mm thick . Figure

2.a shows the SCB's whole front perspective, and Figure 2.b shows the suggested antenna structure. On the substrate's top layer, the monopoles itch. The ground plane has not received any additional available slots, and Feeding is done by Microstrip Line Feed. Table 1 displays the intended antenna's dimensions. The dimensions of the intended antenna are shown in Table 1.



(a)

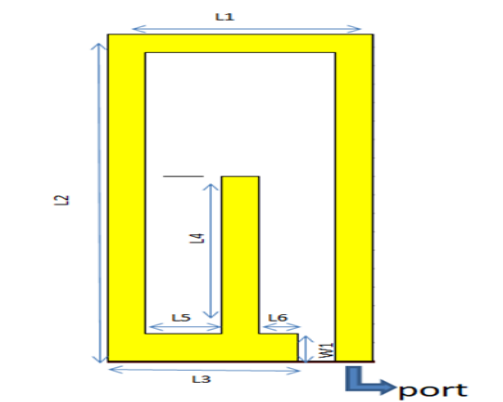

(b)

- MONPOLE PLANE
- SUBSTRATE OVER GROUND

Fig.(2):- The Proposed Antenna (a) shows the position and front of Proposed Antenna, (b) Antenna structure.

Table (1):-The values of the monopoles' lengths

symbol	length	symbol	length
L1	7	L5	2
L2	17.7	L6	1
L3	5	W1	1.5
L4	8.5	W2	1

3.SIMULATION RESULTS AND ANALYSIS

The suggested antenna design has been manufactured, and the port of the microstrip feed line is connected to a SMA connection as shown

in Figure 3. On top of the FR4 substrate, the System Circuit Board (SCB) is constructed. It should be noted that the suggested antenna's bandwidth spans 2.35 to 3.74 GHz. The LTE 4G and 5G NR bands are covered by this B.W.

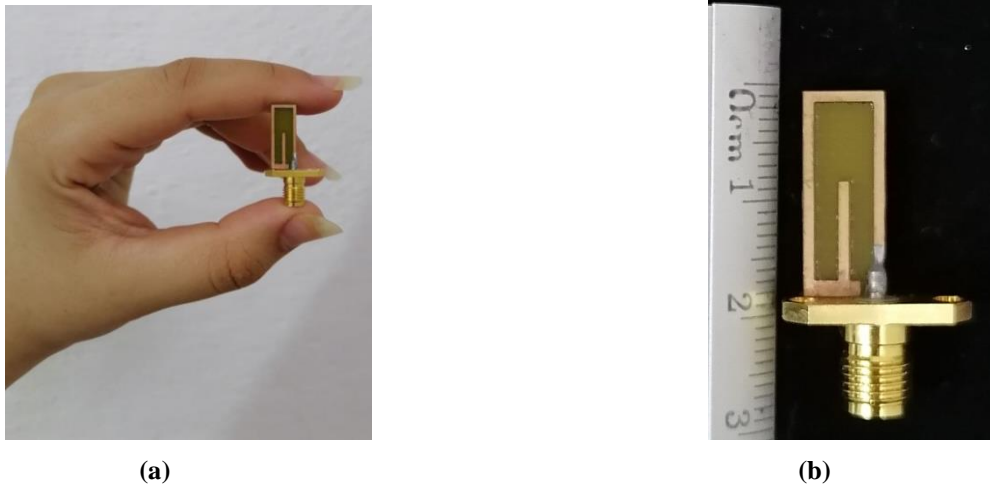

Fig.(3) (a) .fabricated antenna for the hand (b) . The manufactured antenna relative to a ruler

When impedance matching is crucial in RF circuits, one measurement that is frequently utilized is the return loss, as shown in Figure 4. The return loss technique (RL) is similar to the

voltage standing wave ratio (VSWR), however VSWR is inappropriate since RL is frequently employed in extremely small quantities relative to wavelengths[13].

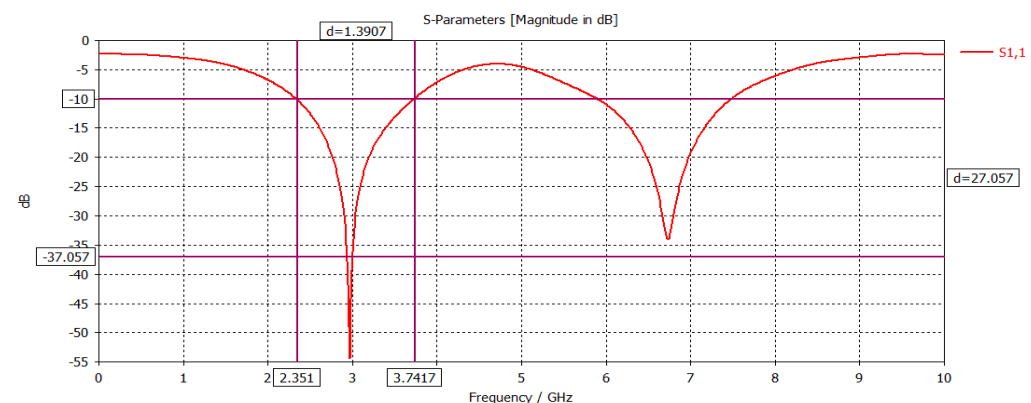

Fig.(4):- S11 of Suggested Antenna at Bandwidth between 2.35GHz – 3.74 GHz

The highest to minimum voltage on a loss-free line is used to establish the voltage standing wave ratio, or VSWR. The VSWR is Voltage Standing Wave Ratio, specifically addresses voltage standing waves that have formed on a feeder or transmission line[7]. Because voltage standing waves are easier to detect and, in many circumstances, voltages are

more significant in terms of device failure, the term "VSWR" is widely used, especially in the disciplines of RF design. is always a real positive value for antennas[14]. The necessary VSWR is 1. For a typical, dependable communication, the VSWR must be between 1 and 2. The final VSWR simulation result is depicted in Figure 5 of the design.

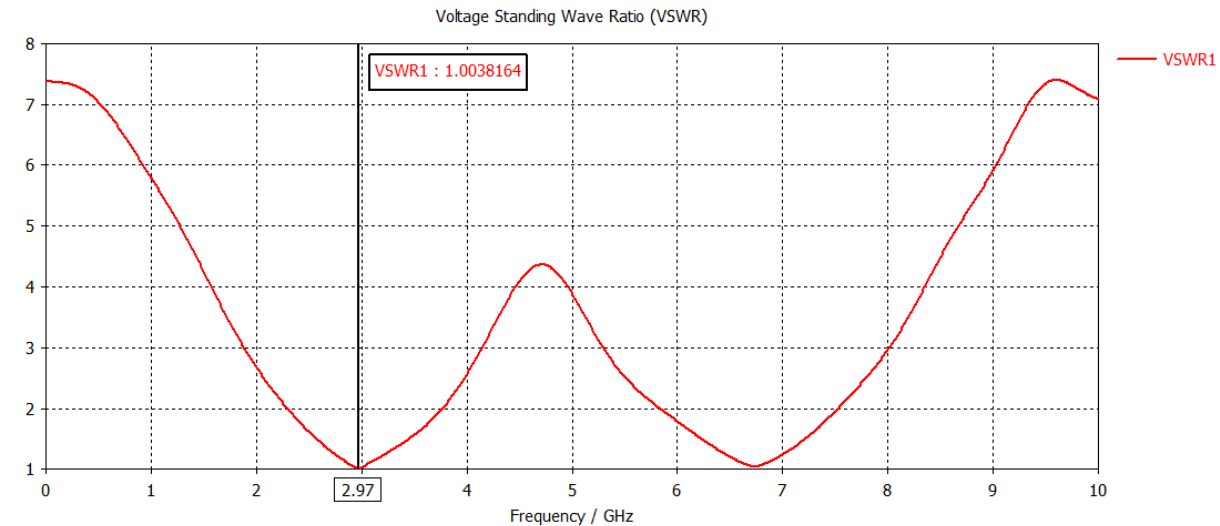
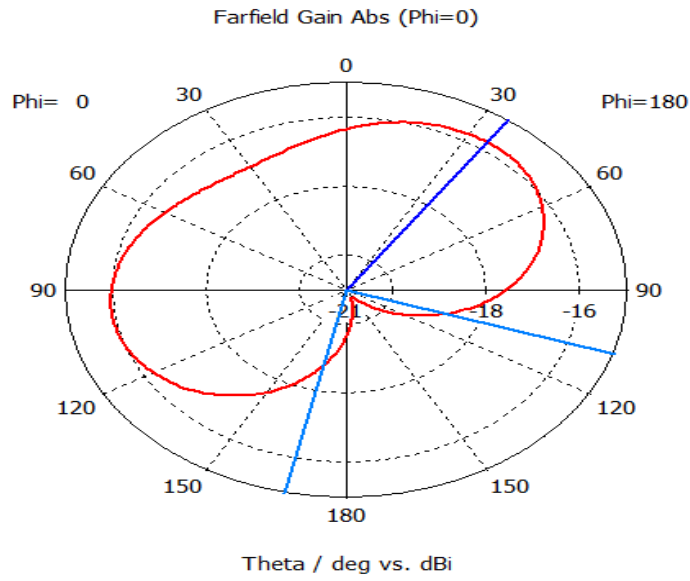

Fig.(5):- The value of VSWR at (2.35-3.74GHz)

In the field of antenna design, the angular dependence of the strength of the radio waves from the antenna or other source is referred to as a "radiation pattern," "antenna pattern," or "far-field pattern" .In the fields of fiber optics, lasers, and integrated optics, the phrases "radiation pattern" and "near-field pattern" are occasionally used interchangeably.[4] This is a reference to the positional dependency of the electromagnetic field in the Fresnel zone or near field of the source. A plane in front of the source or a sphere or cylinder that surrounds it are frequently used to define the near-field pattern

.The radiation pattern from an antenna can be calculated from the near-field pattern of the antenna. At an antenna range, an antenna's far-field pattern can also be identified experimentally.[1] Using computer programs (CST), the far-field pattern can also be deduced from the antenna geometry. Figure 6 depicts the proposed antenna's pattern at 2.97 GHz frequencies. The H-plane (x-y plane), the E-plane (y-z plane), and the x-z plane are used to show the radiation pattern. Figure 6. Shown the polar radiation plot of the final design antennas at around 2.35 -3.74 GHz.



(a)

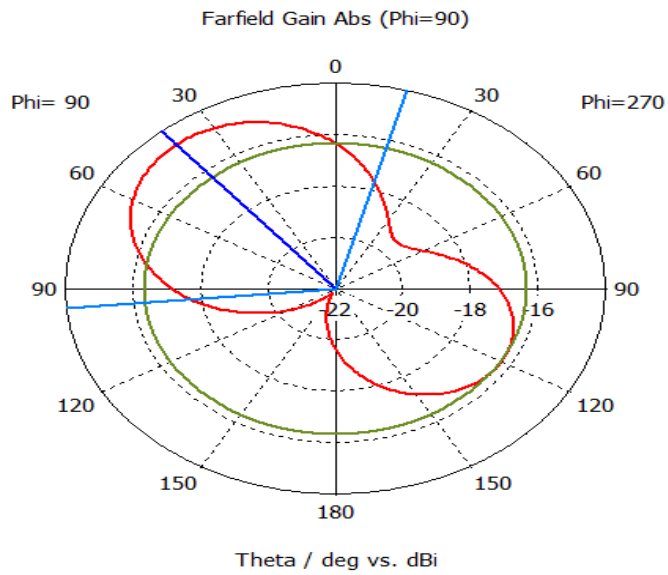

(b)

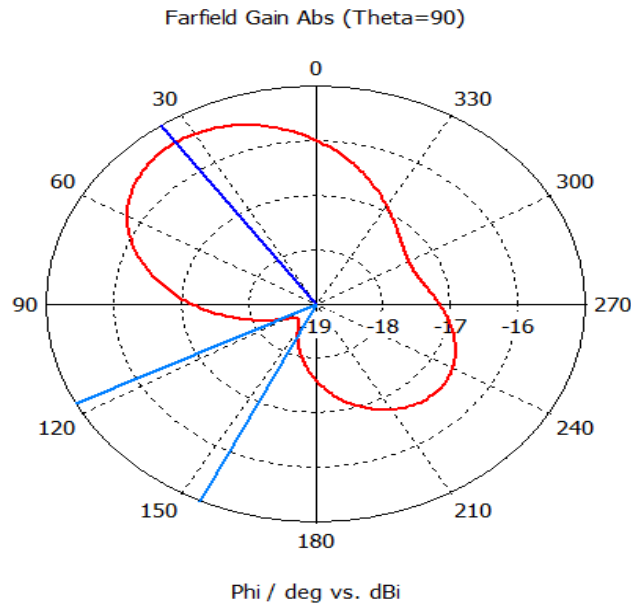

(c)

Fig.(6):- Simulated 2D radiation pattern at around 2.35 -3.74 GHz,(a) phase 0,(b) phase90 (c)theta 90.

The directivity of an antenna is defined as the ratio of the maximum power density $P(\theta,\phi)_{max}$ to its average value over a sphere. The frequency directivity ratings in the low-high band are both higher than one[2]. This antenna's directivity operates between 2.35 GHz and 3.74 GHz and is 2.44 dBi when FR-4 lossy

is used as the substrate. It is common to talk about the broadcast signal's power and directional properties shown in Figure 7. The gain of antenna is relatively strong in contrast to more current designs. The antennas' gain is around 14 dBi at 2.35 to 3.74 GHz. Figure 8. displays these findings.

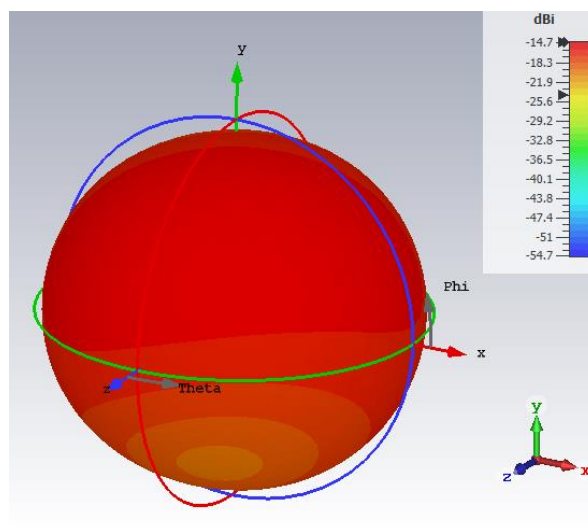

Fig.(7):-The directivity of proposed antenna at around 2.35 -3.74 GHz

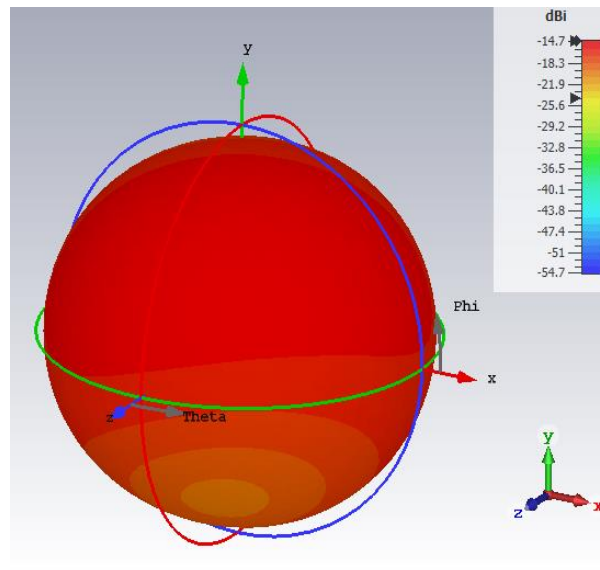

Fig.(8):-Gain of proposed antenna at around 2.35-3.74GHz

4. CONCLUSION

This work introduces a new antenna that functions with both 4G and 5G mobile communication platforms. The SCB's overall dimensions of 150 x 80 mm² enable it to fit within the majority of commercial cell phones thanks to the design and simulation of the antenna. The antenna, which is 17.7x7 mm², is situated in the substrate's upper corner. The antenna consists of a stub, numerous monopoles of different sizes and shapes, and no open ground plane slots. Different frequency bands were affected differently by each antenna

component. This antenna configuration operates between 2.35 and 3.74 GHz. Given that it satisfies the required design specifications and takes up little space.

5. RELATED WORK COMPARISON WITH THE PROPOSED MODEL

After reviewing the previous theses conducted in the field of antennas. in this section of the research, we compare the results obtained from this antenna that we designed, manufactured with four of the previously mentioned researches. This comparison is shown in the table 2.

Table (2):- Related work Comparison of proposed model in terms of antenna elements

Researcher	material	Dimension	Range of frequency	The result	Application
M.Khalifa. [1]	Copper Fr-4	and 22mm×11.7mm	1.24 GHz -2.64 GHz 3.34 GHz – 5GHz	S11= - 35dBi Gain = 4.2-6 dBi	Communication (5G)
M.Pachiyannan [4]	Do mention	not 6mm × 8 mm	2.25 GHz –2.85GHz	S11= - 34dBi Gain =do not mention	Wireless Application
L.p.Mishra [5]	Copper Fr-4	and 10mm × 8mm	3.5GHz – 4.3GHz	S11= - 35dBi good gain vestigate	Satellite Application
r.Bhanumathi [6]	Copper Roger RT	and 24 × 36 mm	5.2GHz – 7.4 GHz	S11= - 25dBi Efficiency 28%	VWR Application
Proposed model	Copper Fr-4	and 17.7mm× 7mm	2.35GHz – 3.74GHz	S11= - 54dBi Gain = 4.42dBi	5G/4G smartphone

ACKNOWLEDGMEN

We extend our sincere thanks to the Iraqi Ministry of Science and Technology for their distinguished efforts in manufacturing and testing the antenna in their scientific laboratories.

REFERENCES

- Y. Li, C. Sim, Y. Luo and G. Yang, "12-Port 5G Massive MIMO Antenna Array in Sub-6GHz Mobile Handset for LTE Bands 42/43/46 Applications," in *IEEE Access*, vol. 6, pp. 344-354, 2018
- A. Pachiyannan, V. Kasinathan, and M. Jayaraj, "E-Shape Microstrip Patch Antenna Design for Wireless Applications," *International Journal of Innovatives Science Engineering and Technology (IJSET)*, vol. 1, no. 3, pp. 484-490, 2014.
- V. Bhanumathi and S. Swathi, "Bandwidth Enhanced Microstrip Patch Antenna for Uwb Applications," *Online) Ictact Journal on Microelectronics*, vol. 1680, no. January, p. 4, 2019.
- "LTE Band chart," RFMW. [Online]. Available: https://www.rfmw.com/data/RFMW_LTE_Band_Chart.pdf
- G. S. Kunturkar and P. L. Zade, "Design of Fork-shaped Multiband Monopole," pp. 281-285, 2015.
- M. Z. A. A. Aziz, B. I. Asadingo, H. Nornikman, M. H. Ramli, B. H. Ahmad and M. A. Othman, "Fork-like shaped monopole antenna with defected parasitic elements and ring slots," 2014 IEEE International Conference on Control System, Computing and Engineering (ICCSCE 2014), Batu Ferringhi, pp. 322-325, 2014
- SS Ahmed, JF Mahdi, Mohammed About Kadhim Design of Ultra-Wideband Microwave Antenna Array for Detection Breast Cancer Tumours. IOP Conference Series: Materials Science and Engineering 881 (1), 012112
- Mohammed About Kadhim, MF Mosleh, SA Shandal Wideband Square Sierpinski Fractal Microstrip Patch Antenna for Various Wireless Applications MA Kadhim, MF Mosleh, SA Shandal IOP Conference Series: Materials Science and Engineering 518 (4), 042001
- IS Ahmed, JF Mahdi, HS Hamid, Mohammed About Kadhim, SS Ahmed Design and Implementation a Multi-Rhombus Patch Fractal Antenna Structure for Human Wearable Device 2022 8th International Conference on Contemporary Information Technology and Mathematics (ICCITM)
- AB Muhajer, JF Mahdi, Mohammed About Kadhim A review of design of ultra-wideband MIMO antenna for breast tumor detection AIP Conference Proceedings 2404 (1), 080005
- Shao, Y. et al. Room-temperature high-precision printing of flexible wireless electronics based on MXene inks. *Nat. Commun.* 13, 3223 (2022)
- Kimionis, J., Georgiadis, A., Daskalakis, S. N. & Tentzeris, M. M. A printed millimetre-wave modulator and antenna array for backscatter communications at gigabit data rates. *Nat. Electron.* 4, 439-446 (2021)
- Martin, A., Chang, B. S., Pauls, A. M., Du, C. & Thuo, M. Stabilization of undercooled metals via passivating oxide layers. *Angew. Chem. Int. Ed.* 60, 5928-5935 (2021).
- Lv, S. et al. Reactive inkjet printing of graphene based flexible circuits and radio frequency antennas. *J. Mater. Chem. C.* 9, 13182-13192 (2021).
- Khorsand Kazemi, K. et al. MXene membrane in planar microwave resonant structures for 5G applications. *Appl. Mater. Today* 26, 101294 (2022).
- Khorsand Kazemi, K. et al. Low-profile planar antenna sensor based on Ti3C2Tx MXene membrane for VOC and humidity monitoring. *Adv. Mater. Interfaces* 9, 2102411 (2022).