

CAPACITY ENHANCEMENT OF RADIO OVER FIBER SYSTEM USING VARIOUS MODULATION TECHNIQUES

LANA LAEQ IBRAHIM and SALIH MUSTAFA S.ATROSHEY
College of Engineering, University of Duhok, Kurdistan Region- Iraq

(Accepted for Publication: November 27, 2023)

ABSTRACT

The recent decade is an era of the 5G and more communication system technology. It has a wide range of application which requires wide bandwidth and high speed of bit rate. Also, Radio frequency and optical fiber is combined in order to attain high capacity transmission at lower costs which Radio over Fiber (RoF) is being as present trend of large broadband communication. This study investigates the RoF-Dense Wavelength Division Multiplexing (DWDM) system in order to enhance the capacity and performance of the system, and simulation was done by using optisystem software 14. The goal of the study was to enhance the number of channels and data transmission rate which the performance of the system was extremely reduced. Hence, different modulation techniques including Frequency Modulation (FM), Phase Modulation (PM), Frequency Shift Keying (FSK), and Continuous Phase Frequency Shift Keying (CPFSK) were presented for the DWDM-RoF system for various sample channels including ch1, ch8, ch16, ch24, and ch32 respectively. In addition, the performance of proposed DWDM-RoF system enhanced, which optimum value of Q factor and minimum BER was attained with FM modulation techniques as a comparison with other modulation techniques including PM, FSK, and CPFSK respectively.

KEY WORDS: RoF, DWDM, FM, PM, FSK, CPFSK

1. INTRODUCTION

Since 1990, various techniques and methods have been advanced in order to transmit large amount of data over long distance optical fiber communication system at high data rate capacity and fast internet for broadband wireless access and multimedia application (Mahmood and Ahmed, 2018). In addition, future broadband access networks provide cost efficient and high data transmission rates in order to support huge number of modern broadband end customer service (El-Nahal, 2013). One of the main access network solution to obtain high speed communication system depend on optical fiber for conveying radio signals known as Radio over Fiber (RoF). It is the combination of optical and wireless system which can be used as a practical solution to enhance the capacity for both mobile and fixed user (El-Nahal, 2013). Also, RoF is the technique which used to modulate radio signal and light signal and transmit the modulated signal over an optical fiber link for expanding wireless access. Moreover, RoF system has planned an advanced performance of radio system which has broad bandwidth for mobile communications (Singh et al., 2017).

The RoF system has many advantages as a comparison with conventional system such as has a tolerant from radio frequency interference, low attenuation, huge bandwidth, low power consumption, operational flexibility, has capability to transmit signal over large distance, and has extend ability for existing capacity and coverage (Beas et al., 2013). In addition, high capacity and velocity is the principal requirement for mobile communication and next generation radio optical fiber which is further needed for a better system to obtain the desires such as Fiber To The Home (FTTH) and Fifth Generation (5G) (Kang et al., 2020). The desire for high speed and large bandwidth can be simply achieved by using optical fiber and an appropriate choice of modulation techniques which could improve the minimum Bit Error Rate (BER) and a better Signal to Noise Ratio (SNR) always required to further improve and restating the RoF communication system with the occurrence of the technology. Also, the integrating of analogue and digital communication such as Amplitude Modulation (AM), Frequency Modulation (FM), Differential Phase Shift Keying (DPSK), Frequency Phase Modulation (FPM), and Offset Quadrature Phase Shift Keying with Amplitude

Modulation (OQPSK-AM) are provided on different optical communication system to further enhance the performance parameters as an example of Quality (Q) factor, BER, and SNR over longer distance incoming in movability as well as decreasing the budget expense in access network (Jawla, 2013).

The academia and industry worldwide have been attracted by the RoF system field to investigate its different design applications and aspects. In (Abdullah Omar Ali et al., 2014) Wavelength Division Multiplexing (WDM) combined with Orthogonal Frequency Division Multiplexing (OFDM) in order to attain high capacity and longer distance for two channels at bit rate of 10Gbps with utilizing Quadrature Amplitude Modulation (QAM) and Phase Shift Keying (PSK) modulation technique. As a result, as a comparison with PSK modulation, high value of SNR obtained with QAM which SNR is 23 and 17dB for QAM and PSK respectively at 50km distance. Also, (Srivastava et al., 2014) designed RoF system with using Minimum Shift Keying (MSK), DPSK, OQPSK, and Continuous Phase Frequency Shift Keying (CPFSK) for two channels. As a result, Optimum performance was obtained with DPSK modulation technique. In (Jalil and AL-Samarrie, 2015), the capacity of RoF system improved for RoF system by combining WDM and Subcarrier Multiplexing (SCM) with different modulation technique such 4,16,and 64 QAM-OFDM for 20 channel with bit rate of 8Gbps. The analysis was done for RoF system with and without OFDM by merging WDM and SCM for 4, 16, and 64 QAM for 4 and 32 channels with bit rate of 5, 7, and 10Gbps at 20km distance. As a result, maximum Q factor and minimum BER was attained with 16 QAM-OFDM (Ali et al., 2018). The effect of equal and unequal channel spacing with Fiber Bragg Grating (FBG) was analyzed by using DPSK modulation technique for four channels with bit rate of 10Gbps at 50km optical fiber length in (Mahmood and Ahmed, 2018). It can be concluded that from the result, high performance obtained with unequal channel spacing. Also, in (Rashed et al., 2018) the performance of the RoF system was evaluated and improved for two channels by using various merging modulation techniques as an example of Quadrature Amplitude Frequency Modulation (QAFM), Pulse Amplitude Frequency Modulation (PAFM), Differential Phase Shift Keying Amplitude Modulation (DPSKAM), OQPSKAM, and FPM which high performance was obtained with FPM

and bit rate was increased up to 160Gbps with DPSKA modulation technique. The performance of RoF system with DPSK modulation scheme evaluated by using various power splitters at the receiver including 1:2, 1:4, and 1:8 respectively for 10,20, and 30km optical fiber distance with data rate of 1Gbps for two channels in (Christine et al., 2019), which low number of noise and high performance was obtained with 1:2 power splitter at 8km distance. In (Ali et al., 2020), the analysis and evaluation was done for RoF system with OFDM and utilizing various modulation technique 4,16,64 QAM for one channel at bit rate of 15Gbps and RF of 5.8GHz.as a result, high performance was obtained with 64 as a comparison with 4,64-QAM-OFDM. An merged modulation technique including QAM-FM and DPSK-FM designed by (Kang et al., 2020). Also, the impact of Erbium Doped Fiber Amplifier (EDFA) and Optical Amplifier (OA) on the designed system has been compared. As a result better performance was obtained with EDFA for QAM-FM and DPSK-FM. Also, maximum Q factor, minimum BER, maximum number of user was attained with DPSK-FM as a comparison QAM-FM. In (Asif Khan et al., 2021), Investigation was done for Centralized Radio Access Network (CRAN) via using RoF with WDM to lessen the effect of Linear Distortions (LDS), Nonlinear impairments (NLS), and phase noise rely on 16,32,and 64 QAM-OFDM which an enhanced Digital Signal Processing (DSP) was performed to the receiver of the proposed system. In (Kumar et al., 2021), The performance of 16channel,160Gbps WDM-RoF system was evaluated with using FBG and Dispersion Compensation Fiber (DCF) with 50 and 100GHz interval between channel. As a result, the performance of the system enhanced with 100GHz as a comparison with 50GHz channel spacing. In (Mohsen et al., 2021), investigation was done for 32x40Gbps data transmission capacity for DWDM-RoF system with channel spacing of 200GHz for a various optical fiber distance of 60,120,and 180km.it can be concluded from the result, the value of BER increased as the distance increased from 60 to 180km.In contrast, the Q factor decreased as the length increased. In (Jain and Iyer, 2021), the analysis was done for 4 channel WDM-RoF system with data transmission rate of 10Gbps and carrier signal of 100GHz at 70km optical fiber distance. As a result, maximum Q factor, minimum BER, and SNR of 6.22, 2.42×10^{-10} , and 61.4 respectively was obtained. In (Bhattacharjee et al., 2022), the

performance of 32 channel based DWDM-RoF system with FBG and DCF was analyzed with bit rate of 8Gbps and optical fiber distance of 60 and 120km. As a result, maximum Q factor of 15.97 was obtained for 50GHz channel spacing. Based on literature review that discussed before, various modulation techniques including DPSK, AM, QAM, PSK, PAM, CPFSK was used for low number of channel and low data transmission rate. In the present study, the impact of various modulation techniques on high number of channel and high data transmission capacity will be investigated. In the proposed system four modulation scheme including FM, PM, FSK, and CPFSK will be utilized for 32 channel DWDM based RoF system with data transmission rate of 40 Gbps at 100GHz channel spacing.

$$s(t) = A_c \cos[2\pi f_c t + \beta \sin(2\pi f_m t)] \quad (1)$$

Where FM modulated signal is represented by $s(t)$, f_c is the carrier frequency, A_c is the amplitude of carrier signal, Modulation index is represented by β , and frequency of input modulating signal is represented by f_m .

2.2 Phase Modulation (PM)

In this type of modulation, the phase of the carrier signal is modified in accordance with the low frequency of the message signal. In other word, the phase of carrier is changed by the information signal without influencing the two other parameter including frequency and amplitude (Lohith K S, 2014, Rashmi Rekha Mishra, 2020).

Assume that the message signal is represented by $m(t)$, carrier signal is represented via $c(t) = A \cos(\omega_c t + K_p m(t))$, PM signal is represented by

$$Y(t) = A \cos(\omega_c t + k_p m(t)) \quad (2)$$

Where k_p is phase modulator sensitivity, ω_c is carrier angular frequency, A is the carrier amplitude.

2.3 Frequency Shift Keying (FSK)

The FSK is FM scheme that digital information is transmitted through discrete frequency changes of carrier signal. Binary Frequency Shift keying (BFSK) is the simplest

2. WAVELENGTH DIVISION MULTIPLEXING (WDM)

2. Material design and method

2.1 Frequency Modulation (FM)

The FM is type of modulation, that the frequency of carrier signal is changed in accordance with message signal, while the amplitude and phase are kept constant. In addition, a frequency modification of the relate frequency of the carrier is utilized by this modulation scheme, and the signal that is modulated and conveyed is analog (Mishra and Parween, Faruque, 2017).

The following equation is used to obtain the demanded FM signal

form of FSK. Also, a couple of discrete frequencies are utilized to imply the BFSK literally in order to transmit binary 0 and 1 information (Middlestead, 2017). Digital binary signal is used to change the frequency of carrier signal. This permits the receiver to recover the digital signal by demodulation. In addition, it can be noticed that the frequency of carrier is varied in accordance with input signal, while amplitude of the carrier signal is not varied after demodulation (Faruque, 2017).

2.4 Continuous Phase Frequency Shift Keying (CPFSK)

The CPFSK is progressed on the fundamental of Minimum Shift Keying (MSK). Which its signal considered as CPFSK signal whose modulation index is 0.5. In addition, this kind of modulation scheme permits the phase of the signal to be persistent. Its internal phase memory characteristic has an ability of error correction and good frequency features in CPFSK modulation. Also, CPFSK has huge bandwidth efficiency which conveys large amount of information in bandwidth, the channel interference is comparatively small, and it is proper for transmission in the nonlinear channel as a result of the attenuation of power spectrum beyond main lobe is comparatively rapid (Lei, 2011). $s(t)$ is stand for the output signal from CPFSK signal (Chaozhu and Ke, 2013).

$$s(t) = A \cos[2\pi f_c t + \phi(t, I) + \phi_0] \quad (3)$$

$$= A \cos[2\pi f_c t + \theta n + \theta(t, I) + \phi_0] \quad (4)$$

Assume a code sequence of M system digital signal $I = I_1, I_2, \dots, I_n, \dots$, where $I_n \in \{\pm 1, \pm 2, \dots, \pm 1(M+1)\}$. Frequency is represented by f_c , initial phase is represented by ϕ_0 , and time

varying of carrier phase is represented by $\phi(t, I)$. Also, the principle function of FM, PM, and FSK is shown in Figure 1.

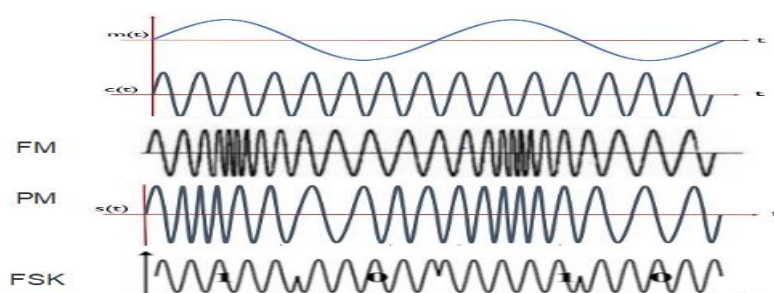

Fig.(1): -Principle function of FM, PM, and FSK modulation technique

This kind of modulation techniques has an advantage among the other modulation techniques e.g. One of the reasons FM is broadly used in radio broadcasting is that it has large of value of SNR and hence resists radio frequency interference which is better than from an equal power of AM. Unlike AM, FM is more strong with signal amplitude fading due to constant amplitude and variation of the frequency (Faruque, 2017). Also, constant amplitude is offered by phase modulation which allows to minimize crosstalk in Dense Wavelength Division Multiplexing (DWDM). As a result, this kind of modulation technique has a robust influence for multichannel system (Urick et al., 2004). In addition, high data transmission rate is supported by FSK and has a low probability of error, and high SNR. Also, it has a resistance from noise as a comparison with Amplitude shift Keying (ASK) and there is no error at the receiver which make it as an appropriated for high frequency radio communication system (Veena and Swamy, 2011). Moreover, The CPFSK is a Continuous Phase Modulation (CPM) method that it is provided with low out of band power and high band utilization advantage. Moreover, this kind of modulation signal is unchanged envelop

signal which is uncomplicated to amplify and transmit in the nonlinear channel (Chaozhu and Ke, 2013).

3. SIMULATION DESIGN

The principal block diagram of the 16 channel, 10 Gbps data transmission rate WDM based RoF system is shown in Figure 2 (Kumar et al., 2021). It contains 16 transmitter and receiver. In addition, Pseudo Random Bit sequence Generator (PRBSG) generated the 10Gbps data signal. Then, Return to Zero (RZ) used to convert the generated data signal into electrical pulse, and then performed to Mach zander Modulator (MZM) to be optically modulated with carrier signal of Continuous Wave Laser (CWL). WDM multiplexer combined 16 optical signal with its identified wavelengths and conveyed into optical fiber link, and signal level is rectified by using optical amplifier after transmitting over long distance. Also, the impact of dispersion is overcome by using DCF and FBG. Finally, all combined wavelength separated at the demultiplexer and transferred to the receiver. At the receiver, the electrical signal is recovered by using Avalanche Photodiode (APD), and noise is overcome by Low Pass Bessel Filter (LPBF).

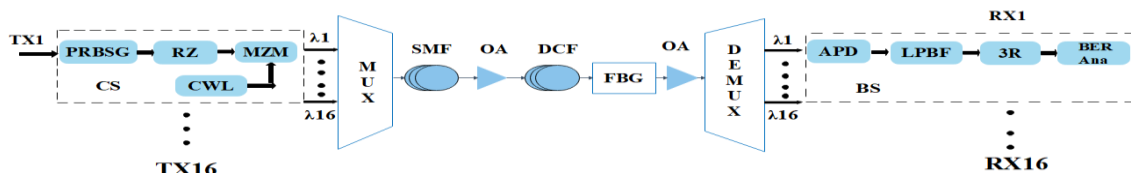

Fig.(2): -16-channel 160Gbps WDM-RoF system (Kumar et al., 2021); PRBSG: Pseudo Random Bit Sequence Generator; RZ: Return to Zero; MZM: Mach Zehnder Modulator; CWL: continuous WaveLaser; OA: Optical Amplifier; SMF: Single Mode Fiber; FBG: Fiber Bragg Grating; APD: AvalanchePhotodiode; LPBF: Low Pass Bessel Filter; 3R:3Regenerator; BER Ana: BER analyzer

The block diagram of the enhanced system is shown in Figure 3 which different kind of modulation techniques including FM, PM, FSK, and CPFSK were used for the system in order to improve the performance of the proposed system,

and electrical filter was utilized at the transmitter after the modulation technique to eliminate unwanted frequency component, also, at the receiver, optical filter was used to permit the required band only to pass.

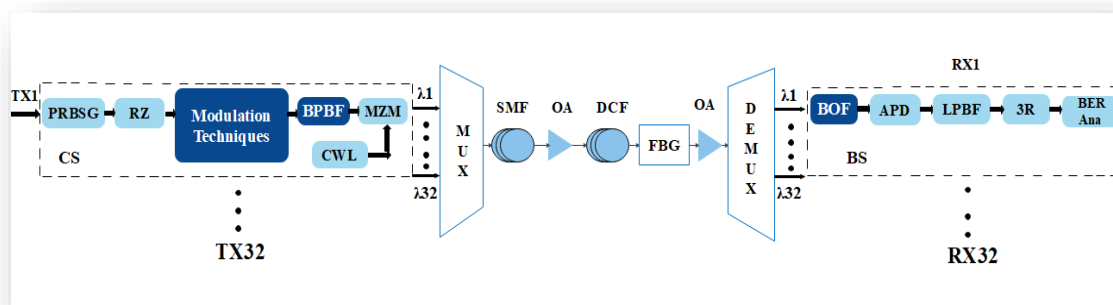
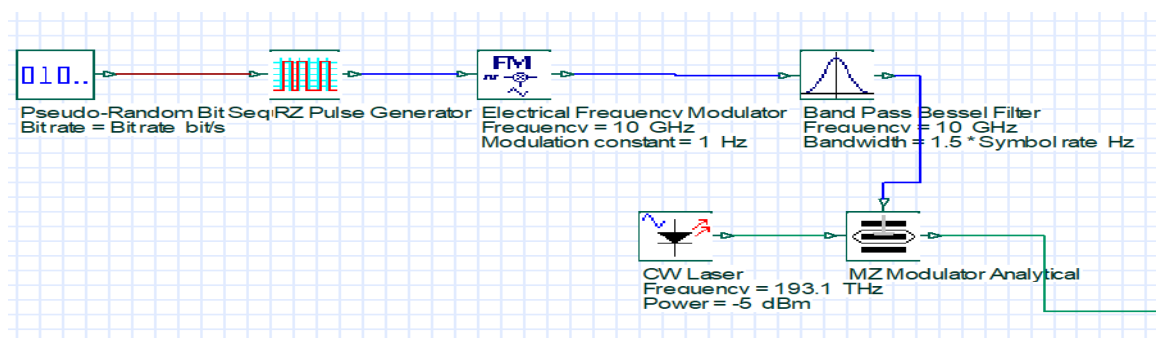

Fig.(3): -An enhanced 32-channel 1.28Tbps WDM-RoF system; PRBSG: Pseudo Random Bit Sequence Generator; RZ: Return to Zero; MZM: Mach Zehnder Modulator; CWL: continuous Wave Laser; BPBF: Band Pass Bessel Filter; OA: Optical Amplifier; SMF: Single Mode Fiber; FBG: Fiber Bragg Grating; BOF: Bessel Optical Filter; APD: Avalanche Photodiode; LPBF: Low Pass Bessel Filter; 3R:3Regenerator; BER Ana: BER analyzer

The construction of the proposed system consists of three stage transmitter, optical transmission medium, and receiver. The transmitter section comprises of 32 channel, which each channel has its own specified wavelengths, that are combined and conveyed over SMF through 50 Km optical fiber link distance by using WDM multiplexer. Moreover, at the transmitter stage, 40 Gbps data signal is generated by PRBSG, and then binary data is changed to baseband digital data signal by using RZ pulse generator (Mohsen et al., 2021,

Rashed et al., 2018). Finally, one of the modulation techniques including FM, PM, FSK, and CPFSK with 10GHz carrier frequency is used in order to electrically or digitally modulate the produced baseband signal (Mahmood and Ahmed, 2018). Also, unwanted frequency components is removed by BPBF with 10 GHz frequency (Mahmood and Ahmed, 2018), before optically modulated with light carrier of CWL by utilizing MZM as exhibited in Figure 4.



(a) FM

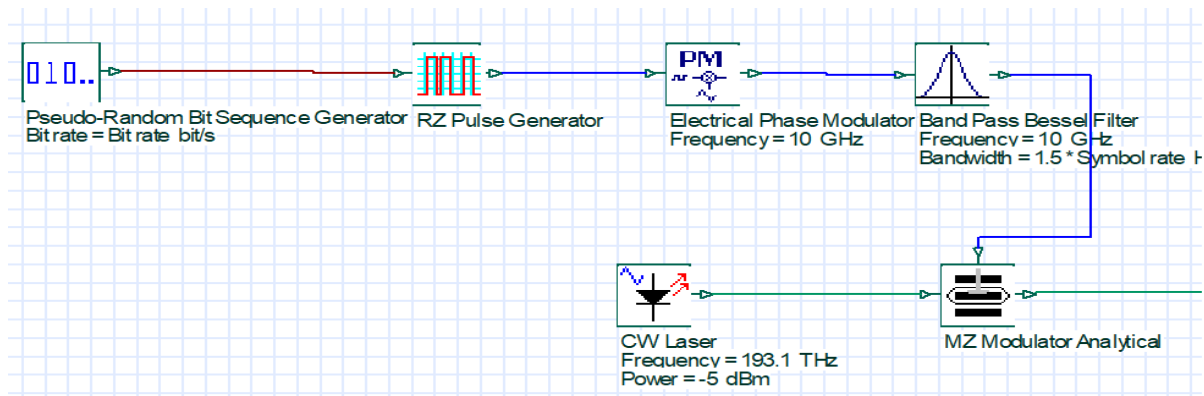

(b) PM

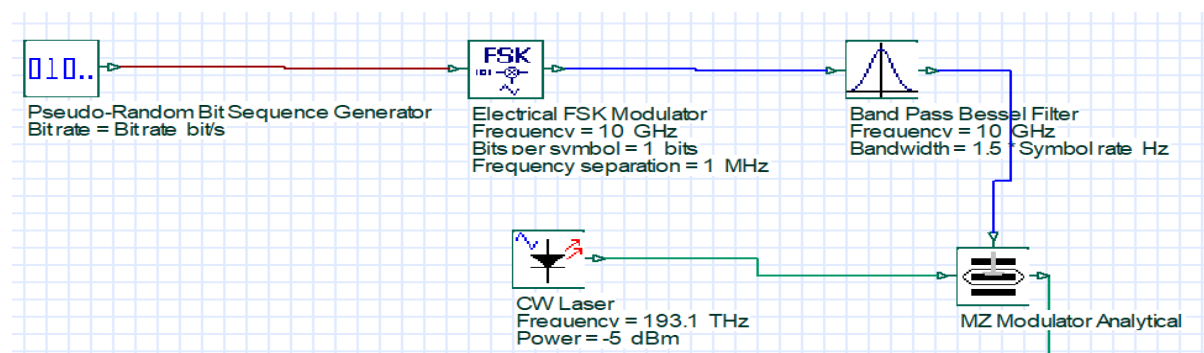

(c) FSK

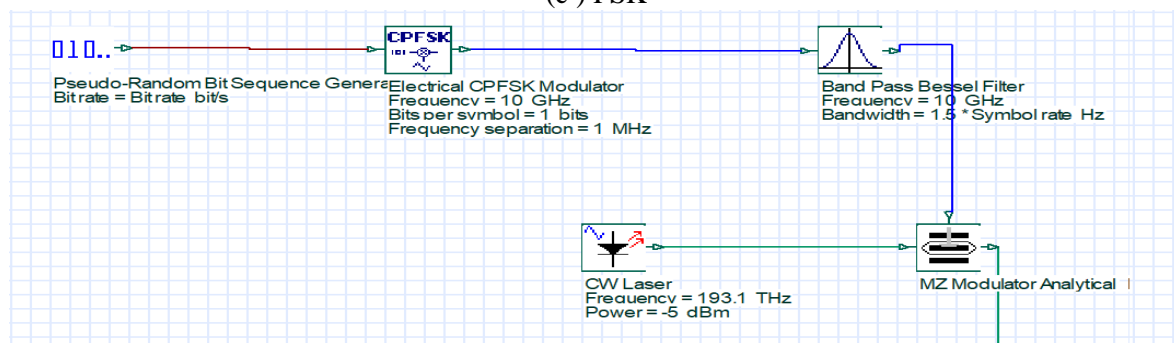

(d) CPFSK

Fig.(4): -Transmitter section of the proposed system for (a) FM, (b) PM, (c) FSK, and (d) CPFSK

At the optical transmission medium stage, after the optical signal of different wavelengths from each CWL are modulated with the electrical signal and after that integrated by using WDM multiplexer to enhance the capacity which wavelength of CWL is set to 193.1THz for the first channel and increased with 100GHz equal channel spacing for the other channel (Kumar et al., 2021). Then, the integrated optical signals are transferred trough Single Mode Fiber (SMF)

through 50km distance, attenuation of 0.2dB/km, and dispersion of 16ps/nm/km (Kumar et al., 2021). Moreover, after the signal is transmitted through 50km distance, Optical Amplifier (OA) is used o decrease the attenuation and rectifies the weak signal level and power with 25 gain and 4dB noise figure (Rashed et al., 2018), and the dispersion and losses of SMF is overcome by using Dispersion Compensation Fiber (DCF) with length of 10km, attenuation of

0.0051dB/km, and dispersion of -80ps/nm/km (Kumar et al., 2021). Also, Fiber Bragg Grating which acts as a filter for wavelength selection is used to remove the effect of dispersion with

193.1THz frequency (Kumar et al., 2021). Finally, after FBG, OA is used to amplify the power as exhibited in figure 5.

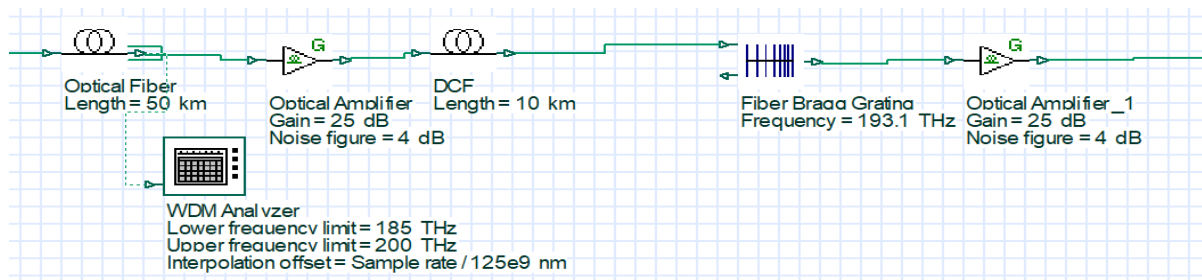

Fig.(5): -Optical transmission link section of the proposed System

The receiver stage as shown in figure 6, Bessel Optical Filter (BOF) is used to permit the demanded band only to pass with bandwidth of 10GHz (Mahmood and Ahmed, 2018). Then, the optical signal is converted to electrical signal by using Avalanche Photodiode (APD), and noise is eliminated by fourth order Low Pass Bessel Filter

(LPBF) and electrical signal is recovered and regenerated with 3R regenerator. Also, the simulation design of the 32 channel, 1.28Tbps DWDM based RoF system is displayed in Figure 7 which simulated by using Optisystem software 14.

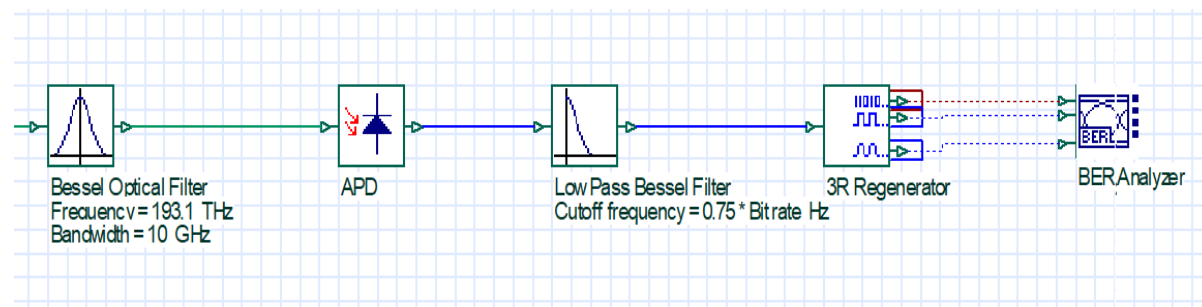

Fig.(6):-Receiver section of the proposed system for the first channel

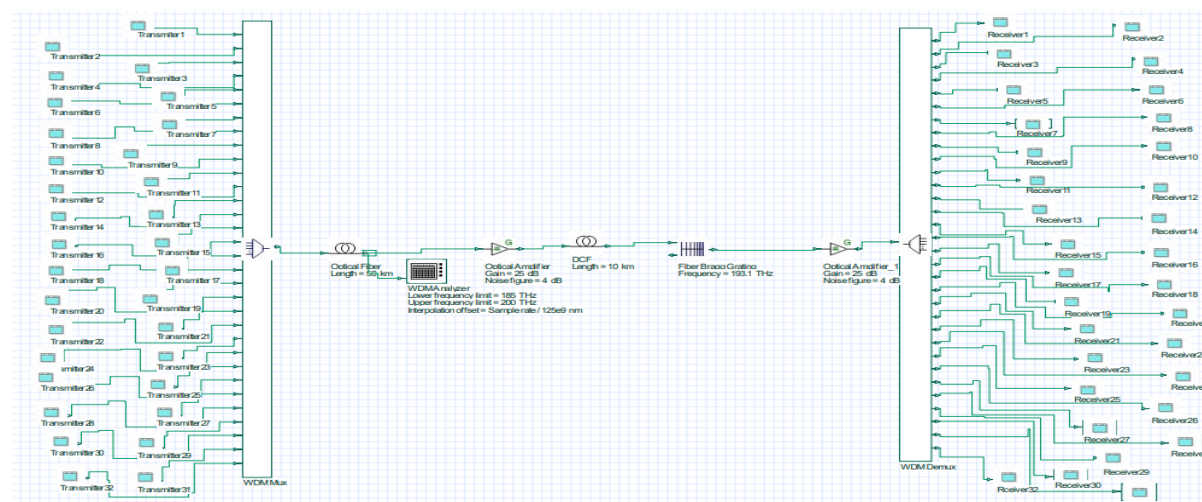

Fig.(7): -The simulation design of the 32 channel DWDM based RoF system

4. RESULT AND DISCUSSION

After the improvement was done for the (Kumar et al., 2021) system which number of channel enhanced from 16 to 32, and bit rate increased from 10 to 40Gbps. The performance of the system greatly decreased after enhancement at 100GHz channel spacing which maximum Q factor and minimum BER of 5.77 and 3.12e-9 was obtained. In the recent study, four proposed

different modulation techniques including FM, PM, FSK, and CPFSK was demonstrated for 32 channel, 40 Gbps DWDM based RoF system to exhibit the impact of this proposed modulation techniques over large number of channels and high bit rate. Based on list of parameters value that are displayed in Table 1 which is set based on literature, the proposed system has been simulated.

Table (1):- The simulation parameters of the proposed system

Transmitter parameters	Value (unit)	SMF & DCF parameters	Value (unit)	Optical amplifier & FBG parameters	Value(unit)
Bit Rate	40 Gbps	Attenuation	0.2dB/km	Gain	25dB
CW laser power	-5dBm	Length	50km	Noise figure	4dB
Channel spacing	100GHz	Dispersion	16ps/nm/km	Effective index	1.45
The frequency of CW laser	193.1-196.2 THz	Dispersion slope	0.074ps/nm ² /k	Length	2 mm
Bandwidth	35GHz	Length	10km	Gauss parameter	0.5
Carrier frequency	10GHz	Attenuation	0.0051dB/km	Linear parameter	0.0001 μm
Sequence length	64	Dispersion	-80ps/nm/km	Bessel optical filter parameter	Value(unit)
Sample per bit	256	Dispersion slope	-0.3Pps/nm ² /k	Bandwidth	10GHz

In this section, the performance analysis of the four proposed various modulation schemes including FM, PM, FSK, and CPFSK based on Q factor, minimum BER, and SNR for five sample channels including ch1, ch8, ch16, ch24, and ch32 respectively are discussed. Also, the

simulation results of proposed system with carrier frequency of 10GHz at 100GHz channel spacing with bit rate of 40Gbps rely on maximum Q factor, minimum BER, and SNR for various modulations were displayed in Table 2 for the above sample channels.

Table (2):- Maximum Q factor, minimum BER, and SNR of the four-modulation technique for the five sample channels of the DWDM system at 40Gbps

Performance parameter	Modulation Technique	Channel 1	Channel 8	Channel 16	Channel 24	Channel 32
Maximum Q factor	FM	14.23	13.67	12.5	13.34	11
	PM	13.63	11.77	12.1	12.1	11.5
	FSK	13.7	12.5	12.44	13.4	11.8
	CPFSK	13.2	12.53	13.2	11.79	11.3
Minimum BER	FM	2.77x10 ⁻⁴⁶	7.94x10 ⁻⁴³	3.64 x10 ⁻³⁶	6.8x10 ⁻⁴¹	1.26x10 ⁻²⁸
	PM	1.36x10 ⁻⁴²	2.77x10 ⁻³²	3.7x10 ⁻³⁴	8.27x10 ⁻³⁴	1.1x10 ⁻³¹
	FSK	3.26x10 ⁻⁴³	4.6x10 ⁻³⁶	8.4 x10 ⁻³⁶	2.42 x10 ⁻⁴¹	1.1 x10 ⁻³²
	CPFSK	3.42x10 ⁻⁴⁰	2.61x10 ⁻³⁶	4.2 x10 ⁻⁴⁰	2.27 x10 ⁻³²	6.8x10 ⁻³⁰
SNR	FM	89.195	89.173	89.175	89.21	89.177
	PM	81.76	81.7	81.7	81.72	81.72
	FSK	81.71	81.69	81.71	81.71	81.71
	CPFSK	81.73	81.76	81.76	81.76	81.75

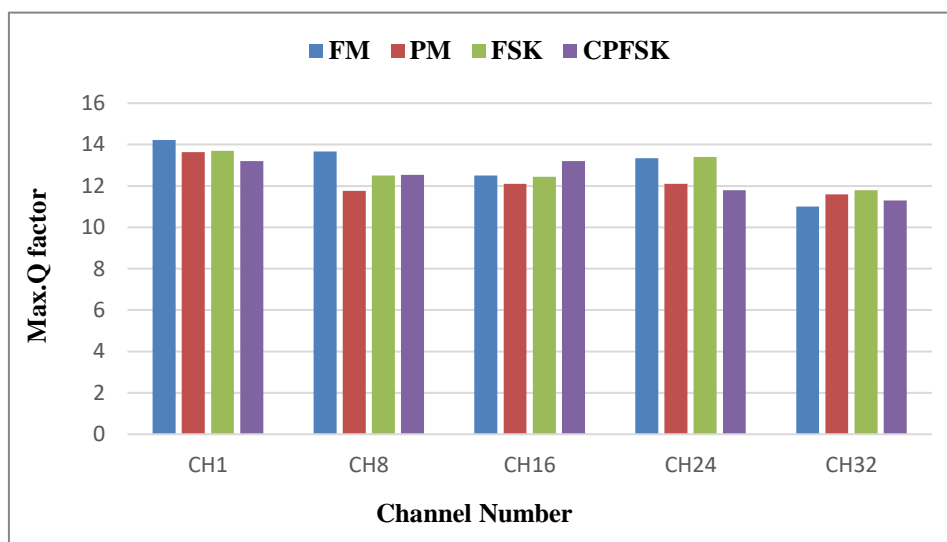

Fig.(8): -Maximum Q factor graph for FM, PM, FSK, and CPFSK at 40 Gbps data transmission rate for Ch1, ch8, ch16, ch24, ch32.

It can be concluded that from figure 8, maximum value of Q factor was obtained in case with proposed FM modulation scheme as comparison with other modulation scheme

including PM, FSK, and CPFSK, which the value of Q factor for optimum modulation technique was 14.23, 13.67, 12.5, 13.34, and 11 for ch1, ch8, ch16, ch24, and ch32 respectively.

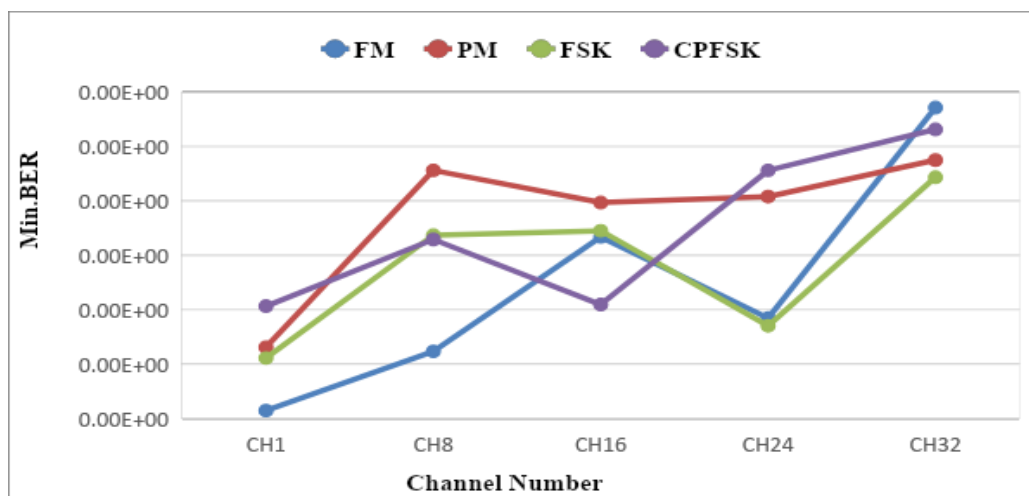

Fig.(9): -Minimum BER graph curve for FM, PM, FSK, and CPFSK at 40 Gbps for Ch1, ch8, ch16, ch24, ch32 respectively

Moreover, minimum value of BER was obtained with FM modulation technique as a comparison with PM, FSK, and CPFSK, which the value of minimum BER for optimum modulation

technique was 2.77×10^{-46} , 7.94×10^{-43} , 3.46×10^{-36} , 6.8×10^{-41} , and 1.26×10^{-28} for ch1, ch8, ch16, ch24, and ch32 respectively.

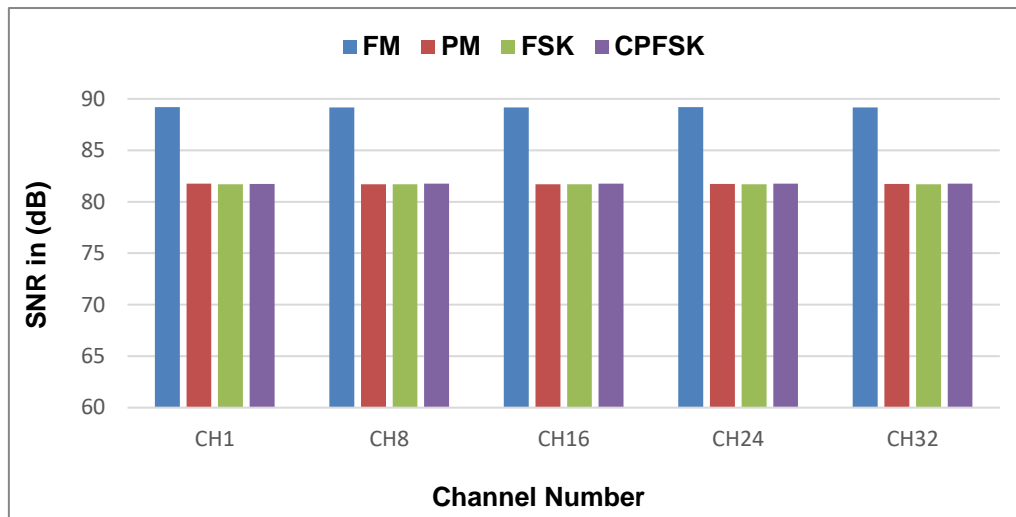
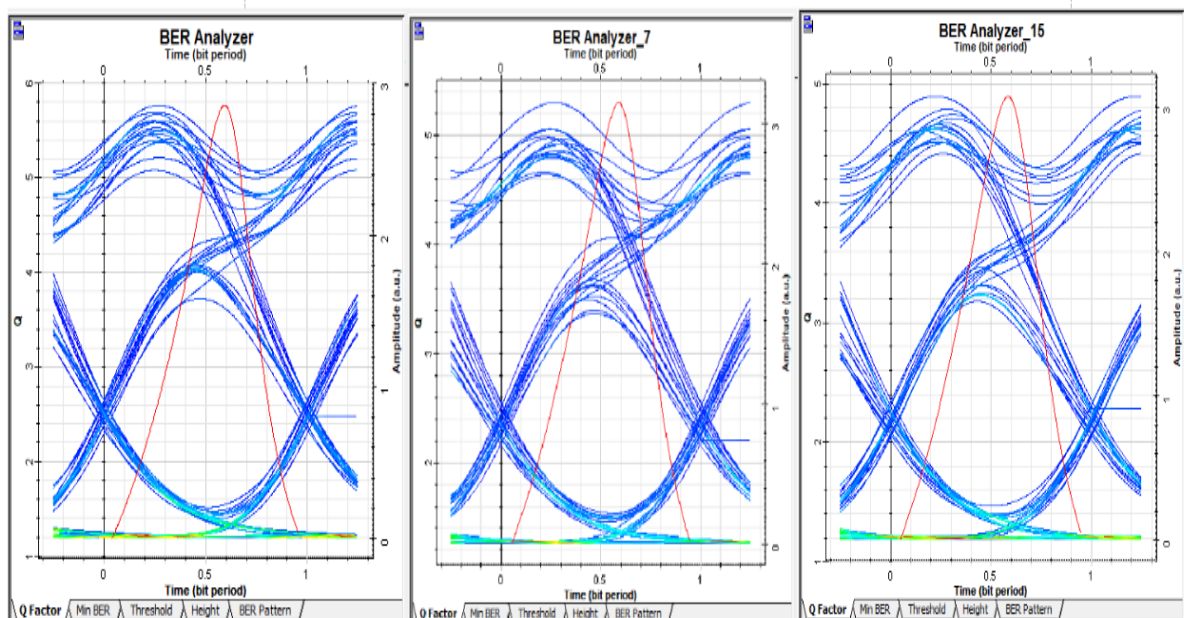

Fig.(10): -SNR graph for FM, PM, FSK, and CPFSK at 40Gbps for sample channels ch1, ch8, ch16, ch24, and ch32.

It can be observed that from figure 13, optimum value of SNR was attained with the proposed FM modulation scheme as a comparison with the three modulations scheme including PM, FSK, and CPFSK, which was 89.195, 89.173, 89.175, 89.21, and 89.177 for ch1, ch8, ch16, ch24, and ch32 respectively which inter Symbol Interference (ISI) is very low at high SNR.

The eye diagram for DWDM based RoF system when FM modulation technique is not provided and used as shown in Figure 11 for various sample channels including ch1, ch8, ch16, ch24, and ch32. In addition, distortion and low eye height can be concluded in the eye diagram.



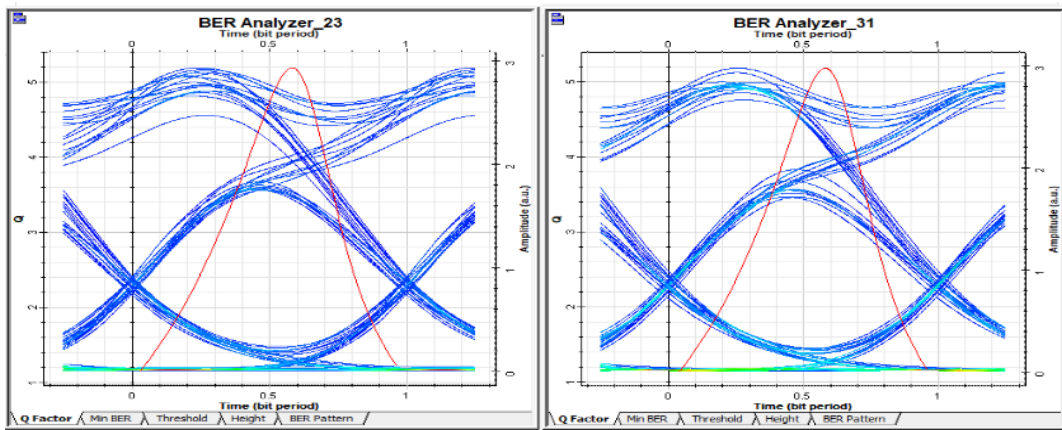
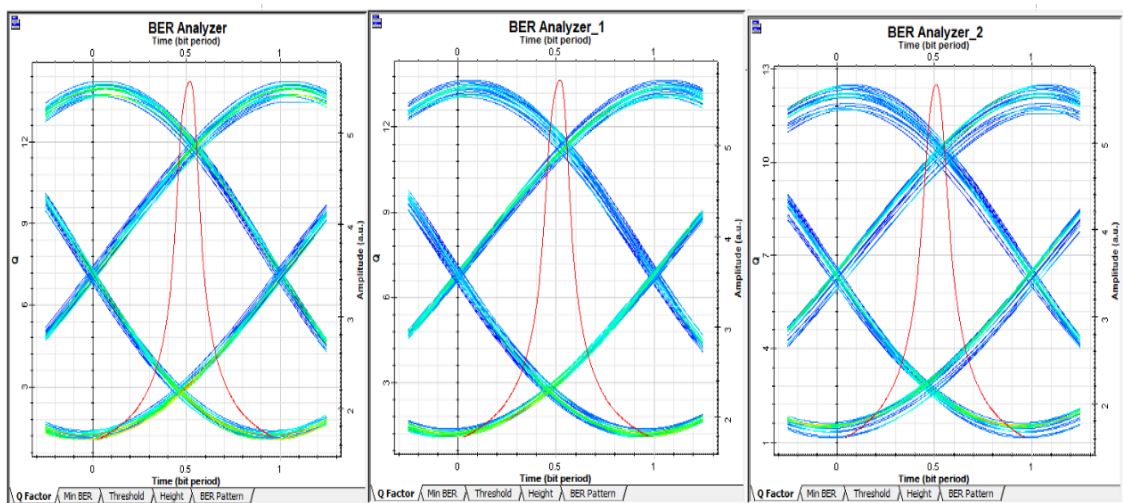

Fig.(11):- The eye diagram for 32 channels DWDM RoF system without utilizing FM modulation technique for sample channels ch1, ch8, ch16, ch24 & ch32.

The eye diagram for DWDM based RoF system when FM modulation technique is considered and used at 100GHz channel spacing and data transmission of 40 Gbps as shown in Figure 12 for various sample channels ch1, ch8, ch16, ch24, and ch32. Also, distortion is reduced and eye high of the eye diagram increased. Also, the value of Maximum Q factor and minimum BER for the five sample channels of the DWDM system at 40Gbps for two cases with utilizing FM and without utilizing FM modulation technique is displayed in Table 3. In addition, it can conclude that from the result after FM modulation technique has been utilized, the value of Q factor increased from 5.77, 5.3, 4.89, 5.2, and 5.19 to 14.23, 13.67, 12.5, 13.34, and 11.04 for ch1, ch8, ch16, ch24, ch32 respectively. Also, the value of

BER is enhanced from 3.12×10^{-9} , 4.5×10^{-8} , 3.67×10^{-7} , 7.99×10^{-8} , and 8.52×10^{-8} to 2.77×10^{-46} , 7.94×10^{-43} , 3.64×10^{-36} , 6.8×10^{-41} , and 1.26×10^{-28} for ch1, ch8, ch16, ch24, and ch32 respectively. Also, higher eye height and minimum distortion is observed in the eye diagram of the received data signal that enhanced from 0.94, 0.899, 0.78, 0.86, and 5.19 to 2.1, 2.09, 2.05, 2.04, and 1.99 for ch1, ch8, ch16, ch24, and ch32 respectively. Therefore, high SNR is obtained in the 32 channel DWDM system. Also, Frequency and modulation constant parameter is a critical design parameter in FM technique which must be chosen properly. In addition, in the proposed system frequency parameter has been selected depend on literature and modulation constant is set as a default value of the parameter.



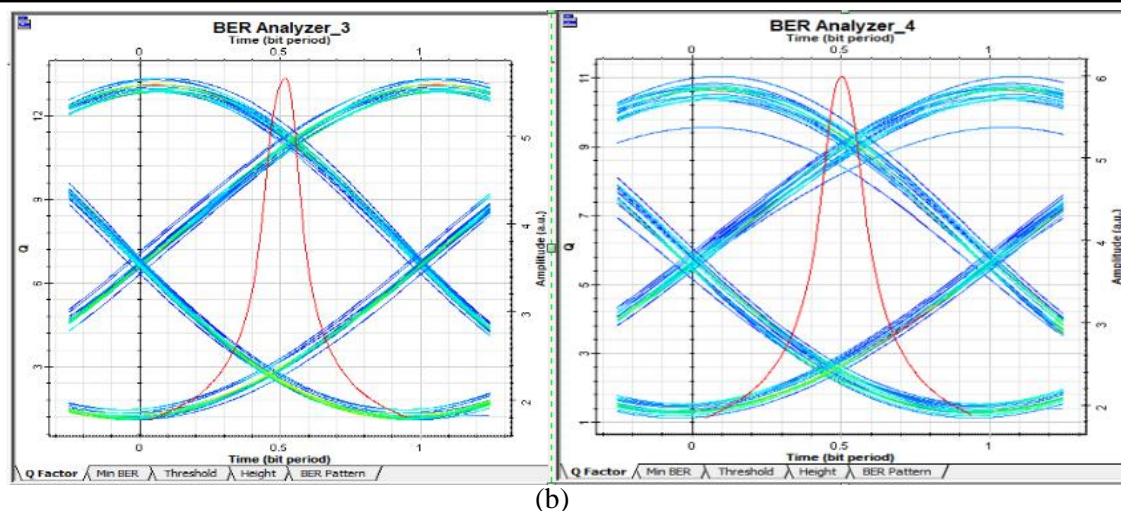

Fig.(12): -The eye diagram for 32 channels DWDM RoF system with utilizing FM modulation technique for sample channels ch1, ch8, ch16, ch24 & ch32.

Table (3): -Maximum Q factor and minimum BER for the five sample channels of the DWDM system at 40Gbps for two cases with utilizing FM and without utilizing FM modulation technique

Case	Performance parameter	Channel 1	Channel 8	Channel 16	Channel 24	Channel 32
Without-FM modulation techniques	Maximum Q factor	5.77	5.3	4.89	5.2	5.19
	Minimum BER	3.13×10^{-9}	4.48×10^{-8}	3.67×10^{-7}	7.99×10^{-8}	8.52×10^{-8}
With-FM modulation technique	Maximum Q factor	14.23	13.67	12.5	13.34	11
	Minimum BER	2.77×10^{-46}	7.94×10^{-43}	3.64×10^{-36}	6.8×10^{-41}	1.26×10^{-28}

6. CONCLUSION

In the recent work, a 32 channel, 1.28Tbps DWDM-RoF system has been analyzed and simulated by using Opti system software 14 for various modulation techniques including FM, PM, FSK, and CPFSK in order to improve the performance of the system with channel spacing of 100GHz and data transmission rate of 40Gbps. The comparison has been done for various modulation schemes based on performance parameter metrics such Q factor, BER, and SNR respectively. As a result, maximum value of Q factor and minimum value of BER has been obtained with FM modulation technique in comparing with the other three modulation techniques which was 2.77×10^{-46} , 7.94×10^{-43} , 3.64×10^{-36} , 6.8×10^{-41} , and 1.26×10^{-28} for ch1, ch8, ch16, ch24, and ch32 respectively. Also, as a comparison with traditional RoF-DWDM system when FM modulation technique is not used, the value of Q factor with FM modulation technique has been improved, and the value of BER is enhanced as mentioned above. Moreover, high value is acquired in the proposed DWDM-RoF

system. As a result, larger eye opening and minimum distortion is observed in the eye diagram. In future, the proposed DWDM-RoF system can be the best candidate and used for very high data transmission rate capacity and multiplexed channels needed for 5G mobile communication system.

REFERENCES

- ABDULLAH OMAR ALI, A.-D., ALJUNID, S. A., JUNID, S., ADNAN, H. & ANUAR, M. S. 2014. Increasing capacity and suppress the crosstalk by using hybrid optical OFDM/WDM system.
- ALI, F. M., ABDALI, E. A. & TARBUL, M. G. 2018. Performance analysis of radio over optical fiber system with OFDM using multiplexing techniques. *International Journal of Applied Engineering Research*, 13, 10831-10844.
- ALI, F. M., WADDAY, A. G. & BALAKET, R. T. Study The Performance Evaluation of Radio over Optical Fiber System with Optical OFDM using Different Modulation Techniques. IMDC-SDSP 2020: Proceedings of the 1st International Multi-Disciplinary Conference Theme: Sustainable Development and Smart Planning, IMDC-SDSP 2020, Cyperspace, 28-

- 30 June 202, 2020. European Alliance for Innovation, 437.
- ASIF KHAN, M. K., ALI, F., IRFAN, M., MUHAMMAD, F., ALTHOBIANI, F., ALI, A., KHAN, S., RAHMAN, S., PERUN, G. & GLOWACZ, A. 2021. Mitigation of Phase Noise and Nonlinearities for High Capacity Radio-over-Fiber Links. *Electronics*, 10, 345.
- BEAS, J., CASTANON, G., ALDAYA, I., ARAGÓN-ZAVALA, A. & CAMPUZANO, G. 2013. Millimeter-wave frequency radio over fiber systems: a survey. *IEEE Communications surveys & tutorials*, 15, 1593-1619.
- BHATTACHARJEE, R., DEY, P. & SAHA, A. 2022. Implementation of an enhanced 32 channel 256 gbps dwdm based radio over fiber optical system for constricted channel spacing employing fiber bragg grating. *Optik*, 253, 168598.
- CHAOZHU, Z. & KE, L. Design and Implementation of All-Digital CPFSK Demodulator Based on Software Defined Radio. 2013 Third International Conference on Instrumentation, Measurement, Computer, Communication and Control, 2013. IEEE, 817-820.
- CHRISTINE, M., HAMBALI, A. & SUJATMOKO, K. Performance Analysis of Radio over Fiber Network for Indoor Telecommunication Application. 2019 IEEE Asia Pacific Conference on Wireless and Mobile (APWiMob), 2019. IEEE, 19-22.
- EL-NAHAL, F. I. 2013. A bidirectional radio-over-fiber system using differential phase-shift keying signals for downstream and remodulated OOK for upstream. *Optik*, 124, 4682-4684.
- FARUQUE, S. 2017. *Radio frequency modulation made easy*, Springer.
- JAIN, D. & IYER, B. 2021. Design and analysis of high-speed four-channel WDM Radio over Fiber system for Millimeter-wave applications. *International Journal of System Assurance Engineering and Management*, 1-13.
- JALIL, M. A. & AL-SAMARRIE, A. K. 2015. Radio-over-Fibersystem Capacity Improvements by using Wavelength Division Multiplexing and Subcarrier Multiplexing Techniques. *Eng. Technol. J*, 33, 1416-1428.
- JAWLA, S. 2013. Intensity modulation formats in optical communication system. *International Journal of Scientific & Engineering Research*, 4, 584-589.
- KANG, A., BHATIA, S., KAUR, N. & SINGH, K. 2020. Performance evaluation of various hybrid modulation techniques transmitted by EDFA in radio-over-fibre communication. *Journal of Information and Telecommunication*, 4, 295-313.
- KUMAR, S., SHARMA, S. & DAHIYA, S. 2021. WDM-Based 160 Gbps Radio Over Fiber System With the Application of Dispersion Compensation Fiber and Fiber Bragg Grating. *Frontiers in Physics*, 9.
- LEI, X. 2011. *Research and development of narrow-band and high-speed CPFSK modulation-demodulation system based on DSP+ FPGA*. Ph D Thesis. Xian: Xidian University, 2011 (in Chinese).
- LOHITH K S, M. 2014. COMMUNICATION SYSTEMS A LECTURE NOTES BY Mahesh Lohith K. S.
- MAHMOOD, H. A. & AHMED, R. K. 2018. Fiber bragg grating and channel spacing effect in WDM radio over fiber system using DPSK modulation format. *International Journal of Engineering & Technology*, 7, 218-222.
- MIDDLESTEAD, R. W. 2017. *Digital communications with emphasis on data modems: Theory, analysis, design, simulation, testing, and applications*, John Wiley & Sons.
- MISHRA, R. R. & PARWEEN, S. Design of AM, FM, PM, ASK, FSK, PSK Using OptiSystem Simulator.
- MOHSEN, D., HAMMADI, A. & ALASKARY, A. Design and Implementation of 1.28 Tbps DWDM based RoF system with External Modulation and Dispersion Compensation Fiber. *Journal of Physics: Conference Series*, 2021. IOP Publishing, 012026.
- RASHED, A. N. Z., ABDEL KADER, H. M., AL-AWAMRY, A. A. & ABD EL-AZIZ, I. A. 2018. Transmission performance simulation study evaluation for high speed radio over fiber communication systems. *Wireless Personal Communications*, 103, 1765-1779.
- RASHMI REKHA MISHRA, S. P. 2020. Design of AM, FM, PM, ASK, FSK, PSK Using OptiSystem Simulator. *International Journal of Research in Engineering, Science and Management* 3.
- SINGH, R., AHLAWAT, M. & SHARMA, D. 2017. A review on radio over fiber communication system. *International Journal of Enhanced Research in Management & Computer Applications*, 6, 23-29.
- SRIVASTAVA, N., JAISWAL, A. K. & KUMAR, M. 2014. Design and performance analysis of radio over fiber system incorporating differential phase shift keying modulation in high speed transmission system. *IOSR Journal of Electronics and Communication Engineering*, 9, 37-42.
- URICK, V. J., QIU, J. X. & BUCHOLTZ, F. 2004. Wide-band QAM-over-fiber using phase modulation and interferometric demodulation. *IEEE Photonics Technology Letters*, 16, 2374-2376.
- VEENA, M. & SWAMY, M. S. 2011. Implementation of Channel Estimation and Modulation Technique for MIMO System. *International Journal of Wireless & Mobile Networks (IJWMN)*, 3.