

## PERFORMANCE ENHANCEMENT OF RADIO OVER FIBER SYSTEM FOR LONG DISTANCE COMMUNICATION

SAMAN AHMED S. SAFFAR and SALIH MUSTAFA S. ATROSHEY  
College of Engineering, University of Duhok, Kurdistan Region- Iraq

*(Accepted for Publication: November 27, 2023)*

### ABSTRACT

It is well-known that the wireless communications cannot provide long distances, because the radio signals have a limited bandwidth and are susceptible to atmospheric noise and distortion. Recently, the Radio over Fiber (RoF) has become a matured technology in terms of coverage, security, and performance since it utilizes the fiber optic cable as the transmission medium. The RoF is a technology that modulates the optical signal by radio signal and transmit it across a fiber optic cable to extend the transmission length and wireless access. Currently, this technology is used to provide enhanced performance wireless systems due to its large advantages of optical fiber medium and flexibility of wireless communication. This paper provides the implementation, simulation, and enhancement of a currently existing RoF system using Optisystem 14 software to improve the length and performance of a system that is designed to transmit 2 Gbps data rate on single channel of 1300 nm wavelength using an external MZM with an input power of 10 dBm, from 5000 Km with a Bit Error Rate (BER) of  $4.3 \times 10^{-37}$  and Quality Factor (QF) of 12.6667 to 7000 Km with a BER of  $3.34 \times 10^{-56}$  and QF of 15.74. In addition, these improvements are achieved through enhancing the main system parameter such as Continuous Wave Laser (CWL) and Extinction Ratio (ER) of the MZM as well as utilizing several transmission enhancement techniques such as Dispersion Compensation Fiber (DCF), Fiber Bragg Grating (FBG) and optical amplifier (OA). As a result, the length and performance of the proposed system in term of BER and QF are improved with a range of 40 %, 51.35 %, and 24.26 % for system length, BER and QF respectively as compared to the length and performance of the previous system.

**KEYWORDS:** ROF, Transmission Medium Enhancement Techniques, FBG, DCF, OA, Base Station (BS), Central Station (CS).

### 1. INTRODUCTION

It is well known that the fast evolution of the communication technologies and the rapid advancements in the wireless communication systems had a significant influence on the human life [1, 2]. Nowadays, wireless communication has become one of the most essential communication approaches since it is required in a vast number of day-to-day activities and is abundantly utilized in various military and civilian applications [3]. Such that, without it, it would be significantly difficult for people to communicate and exchange their private information like e-health data, online shopping and credit card information [4, 5]. In addition, it is impossible to visualize the human life without the new applications provided by the wireless technologies such as Artificial Intelligence (AI), online video streaming, online gaming, digital money trading, YouTube, etc. In which the

majority of these applications require high speed, large bandwidth and minimum latency [4, 6, 7].

In early beginnings of the telecommunication, wireless network applications like General Packet Radio Service (GPRS) and Global System for Mobile (GSM) could operate with low data rates. However, due to the rapid increase in the amount of mobile subscribers and their significant demand on the bandwidth intensive user applications, modern wireless systems should provide larger bandwidths and higher data rates [8, 9]. As a result, reliable mobility, large bandwidth, and high data rates are considered as the major requirements that should be offered by modern wireless communication networks [4, 6, 10]. However, these requirements cannot be fulfilled directly since the operating Radio Frequency (RF) spectrum is already congested and working in a higher frequency band is significantly complicated [10, 11]. In order to overcome these limitations, two solutions were discovered. The first one was known as Micro or

Pico cell concept, which is the process of decreasing the cells size to support higher number of users [12, 13] and the second solution was to work in a higher frequency band to prevent the spectral congestion in the lower band [8, 14]. Nevertheless, using these methods results in several other issues such that reducing the cell size tends to an increase in the amount of required Base Stations (BSs) to cover the entire service area, which tends to an increase in the overall system cost. On the other hand, operating in a higher frequency band tends to contribute higher equipment's, maintenance, and installation cost [8, 15].

In the past decades, fiber optic transmission has played a significant role in the communication systems, where it was considered as one of the most important and best transmission method in the telecommunication systems [16, 17]. Recently, due to the exponential development in the fiber optic cables and their significant advantages, the traditional copper and coaxial cables has been replaced by optical links to be utilized for larger distances with lower level of attenuations and higher data rates [10, 18]. This replacement has simplified the system design and increased security at physical level [19, 20].

As a result, the large bandwidths, high data rates, and huge data traffics requirements of the modern wireless systems can be controlled through designing a system architecture, whose complicated processes are performed at a Central Station (CS) rather than at the BS, and uses the optical fiber as a transmission medium [9, 12, 21]. One of the most advanced fiber optic technologies

for broadband wireless systems that utilizes the fiber links as a transmission medium was introduced in the beginning of the eighties under the name of Radio-over-Fiber (RoF) [1, 22, 23]. The RoF technology is an integration of both optical and wireless communication systems that provides larger capacity, higher data rate, and reduced latency due to the various advantages provided through utilizing optical fiber medium [19]. These advantages include large bandwidth, reduced power consumption, immunity to radio frequency interference and dynamic resource allocation [15, 24, 25]. This technology has the ability to combine both optical medium and wireless system through distributing the RF signals over several BS using fiber optic cable [22, 26].

Therefore, the development of the RoF technology as a hybrid Fiber-Wireless (FI-WI) communication technology can be considered as a promising solution for long haul and high capacity systems [27]. In addition, this technology is conducted with the objective to transfer the wireless communication for long distances with high Quality Factor (QF) and low Bit Error Rate (BER) [18]. Some of the main applications of these systems are providing the cellular and wireless communication in large countries and states as shown in Fig. 1 that cross thousands of kilometers and controlling the election process without fabrication in uncontrolled areas through transmitting information intercontinentally to controlling center in another country [28, 29].

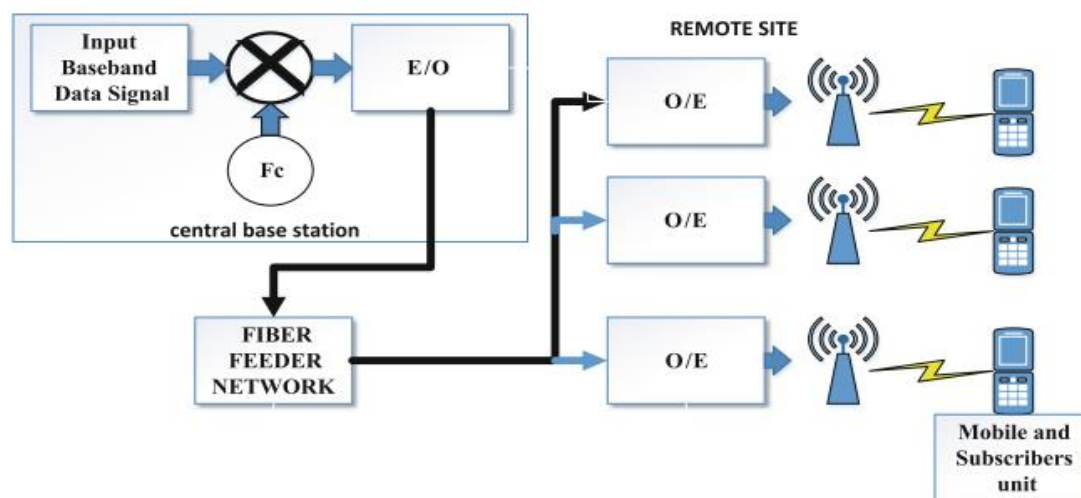

Fig. (1):-The RoF Block Diagram (Prajapati and Maradia, 2018)

As a result, this paper works on a 2 Gbps data rate single channel RoF system for long distance communication, to improve the system length from 5000 Km to largest possible distance with minimum BER and maximum QF through enhancing system parameters and improving the transmission medium.

## 2. The Radio over Fiber Technology

Recently, due to the huge demand for broad band wireless access and moving to higher frequency band, the integration of wireless and optical communications became as a promising solution for succeeding generation of mobile communication [30]. In which this integration increases the system capacity and mobility as well as decreases the system cost [17, 20]. One of the most sophisticated communication technologies for broadband wireless access that integrates both fiber and wireless communication together is RoF [16, 31]. The RoF is a crucial optical technology used to facilitate the transmission and wireless access as well as provides an unrestricted access to broad band wireless communication [19, 32]. Nowadays, the reliability and high mobility are the prime requirements of the communication systems, and the RoF technology can be utilized to achieve these requirements through the large bandwidth provided by optical communications, and the flexibility offered by the wireless communications [4]. The main concept behind the RoF technology is the transmission of the radio signals over a fiber optic link, through

modulating the light signal with the Radio Frequency (RF) signal to increase the overall system capacity and extent the wireless access [5].

At the beginning of the 1990's, RoF was used for the first time in mobile and cordless telephone service and was mainly used to make the connection between CS and BS using an optical fiber link [1]. The main aim was to enhance the transmission of the RF signal between the BS and CS and avoid the spectral congestion in the lower frequency band through transmitting high frequency signal, such as millimeter wave on an optical link [4]. In other words, these systems were generally utilized for transportation of the microwave and millimeter wave signals and achieving the mobility functions in the CS [19, 31]. While today's RoF systems are designed to perform several functionalities beside mobility and transportation functions [33]. These functions are signal processing, signal modulation, and up/down frequency conversions. Whereas, complex processes like encoding, modulation, routing, and demodulation are implemented at the CS, while the simple Optical/Electrical (O/E) signal conversions is performed at the BS [4, 34].

Generally, RoF system architecture is composed of three main subsystems. These subsystems are CS as a transmitter, optical fiber link as the transmission medium and a BS as a receiver [15], as shown in Fig.2.

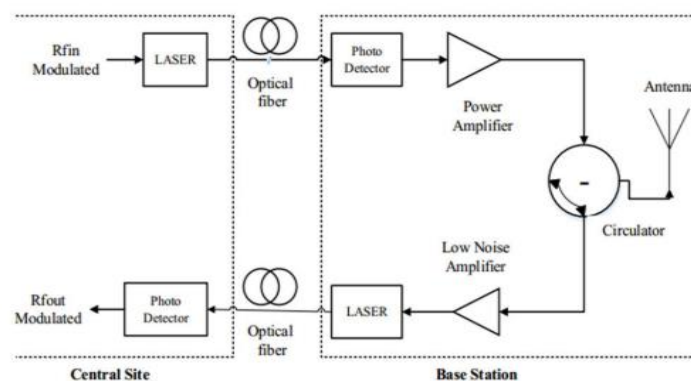

Fig. ( 2):- Main Configuration of the RoF [10].

In which, each of the abovementioned subsystems have their own specific responsibilities and functionalities such that the CS is used to generate the optical signal and transmit it to an optical transmission medium [35, 36]. This process is performed through two main stages, the first stage is the production of the electrical baseband signal from the binary

information and encoding formats through electrical modulation schemes. While the second stage is the generation of the optical signal from the resultant electrical baseband signal and laser light using optical modulation techniques, such as direct or external modulators [37]. Finally, the resulted optical signal can be passed to the optical transmission line directly or using a multiplexing

technique depending on the type of the RoF system whether it is single channel or multiple channel system [10, 38]. On the other hand, the transmission medium is utilized to send the light signal from CS to BS using several optoelectronic devices, such as optical amplifiers, dispersion compensation devices, and required filters. While at the BS, if the system structure is multiple channel, then demultiplexing techniques are utilized to receive and separate the light signals then continue the receiving process [10, 11]. However, if the system structure is single channel, then the resulted signal is directly converted back to the RF signal using a photodetector device along with various required frequency modifying, filtering, and regeneration devices [39]. Similarly, when the transmission is from BS to CS, the BS Receives the RF signals from the subscriber, converts them to optical form using another Modulator and re-transmits them to the CS through optical fiber link. Thus, the RoF system support a single shared location for centralizing the radio signal processing [10, 15, 40].

Generally, RoF system has a limited capacity and can transfer the information only in one

direction as a one-way (simplex) communication [41]. In order to provide a bidirectional (full duplex) communication, two optical fiber links should be used [42]. However, in order to use single fiber link and provide bidirectional transmission, several optical multiplexing techniques are introduced, such as Subcarrier Multiplexer (SCM), Wavelength Division Multiplexer (WDM), Dense Wavelength Division Multiplexer (DWDM), Frequency Division Multiplexer (FDM), Orthogonal Frequency Division Multiplexer (OFDM), etc [6, 19, 43].

### 2.1 RoF Measurements

In order to determine whether the RoF system is operating successfully or not, several performance measurement devices are utilized, such as power meter, BER, and spectrum analyzer. In which the numeric and graphic results obtained from these devices are estimated through several parametric calculations [44]. These parameters and factors are:

**1-** Signal to Noise Ratio (SNR): It estimates the system performance in a noisy medium and is determined as the ratio of the average signal power to average noise power:

$$SNR (dB) = 10 \times \log_{10} \left( \frac{SP_{av}}{NP_{av}} \right) \quad (1)$$

Where:

$SP_{av}$  is Average signal power.

$NP_{av}$  is Average Noise Power.

**2-** Optical Signal to Noise Ratio (OSNR): It is described as the ratio of the optical signal power to optical noise power in a fiber medium and it is expressed in dB as:

$$OSNR (dB) = 10 \times \log_{10} \left( \frac{OSP}{ONP} \right) \quad (2)$$

Where:

$OSP$  is Optical Signal Power.

$ONP$  is Optical Noise Power.

**3-** Noise Figure (NF): It is used to calculate the figure of the receiver merit such that the higher the level of NF the lower the system performance and vice versa. NF is also determined as the ratio of the input SNR to output SNR and is expressed in dB:

$$NF (dB) = 10 \times \log_{10} \left( \frac{SNR_i}{SNR_o} \right) \quad (3)$$

Where:

$SNR_i$  is Input signal to Noise Ratio.

$SNR_o$  is Output signal to Noise Ratio.

**4- Eye Diagram:** It is also known as eye pattern in telecommunications, as shown in Fig. 3, in which it is an intuitive graphical representation of optical signals. It is called so because the pattern represented in this display is similar to a series of eye patterns between a pair of rails. In addition, the opening of the eye corresponds to the amount of distortion available in the system and the signal quality of the system along with the Inter Symbol Interference (ISI) can be examined from the opening of the eye (Johny and Shashidharan, 2012). The eye opening is calculated by the following equation:

$$E_{eye} = I_1(\min) - I_0(\max) \quad (4)$$

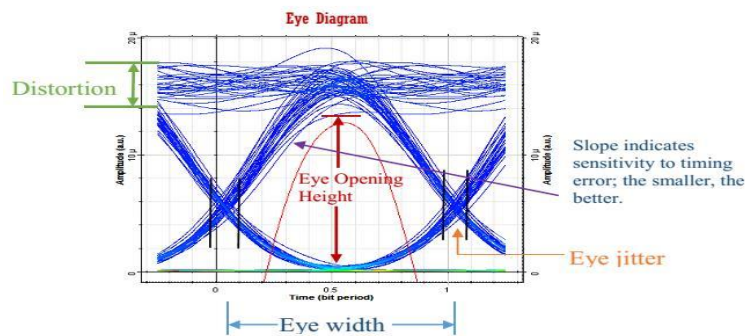

**Fig. ( 3):-**Main Structure of the Eye Diagram.

Where:

$E_{eye}$  is the Eye Opening.

$I_1(\min)$  is Minimum Mean Value of the Upper Line of the Eye.

$I_0(\max)$  is Maximum Mean Value of the Lower Line of the Eye.

**5- Quality Factor (QF):** It is a measurement unit used to calculate the quality of the received signal that is determined in term of eye opening. The QF is determined using the following equation:

$$QF = \frac{E_{eye}}{\sqrt{\sigma_0^2 + \sigma_1^2}} \quad (5)$$

$$BER = (\text{Number of error bits}) / (\text{Total number of transmitted bits}) \quad (6)$$

**7- BER and QF are related as follow:**

$$BER = \frac{1}{2} \operatorname{erfc} \left( \frac{Q}{\sqrt{2}} \right) \quad (7)$$

Where:

$\operatorname{erfc}$  is the Error Function

Where:

$E_{eye}$  is the Eye Opening.

$\sigma_0$  is Variance of 0.

$\sigma_1$  is Variance of 1.

**6- Bit Error Rate (BER):** It is the ratio of the number of bits that are varied in a noisy channel (error bits) to the total number of transmitted bits during the bit interval. BER calculated using the following equation:

8- BER and OSNR are related as follows:

$$\log_{10} (BER) = 10.7 - 1.45 \times [OSNR] \quad (8)$$

## 2.2. RoF system Stages

Generally, all the RoF systems are made with three main stages such as TX, transmission medium and RX as mentioned before [45]. However, since this work is designed for long haul communications, it includes several other stages such as enhancement technique stage and regeneration stage to deliver the wireless communication for largest possible distance with best performance. As a result, this section will explain briefly the design stages of the RoF system used in this work that include the CS or Transmitter (TX) stage, transmission medium, signal regeneration stage, transmission medium enhancement stage, Receiver (RX) stage and wireless distribution stage with their all technologies and methodologies.

**Transmitter (TX):** The transmitter (TX) is considered as the first stage of the RoF systems and is usually called Central Station (CS) because almost all the complex processes are performed in this field. These processes include generation of the binary message, electrical encoding, electrical modulation, and optical modulation [46, 47].

**Transmission Medium:** Generally, in all communication systems, the second stage after transmitter stage is transmission medium that is used to transfer the generated signal from the transmitter station to the receiver station [48]. Also, in RoF systems, the second stage is optical transmission medium that is utilized to transfer the generated optical signal from the CS to several BSs. However, due to the dispersion and signal degradation effects, all the transmission mediums have their own limitations and may not have the ability to deliver the signal with acceptable performance. As a result, beside the transmission medium, several other signal enhancement techniques are used to provide the recipient of the transmitting signal to the required destination with acceptable performance. These techniques include signal amplification, signal regeneration, filtration, and signal enhancement devices [20, 49].

**Receiver (RX):** It is well known that the third stage of any communication system is receiver stage that provides the recipient of the signal from the transmission medium and makes it ready for later use. In RoF systems also, the third stage is receiver stage called BS, which is responsible for

receiving the optical signal from the optical transmission medium and converts back to the RF signal to be used for next stage, which is generally the wireless communication stage [10]. As mentioned before, RoF base stations are differed from traditional BSs since they are only responsible for optical to electrical conversion and simple filtering techniques that enhance the signal quality at the receiver. However, in high capacity multi-channel RoF systems, these BS must include a demultiplexer technique to demultiplex the incoming optical signal, then perform other processes through a photodetector and filtration techniques to provide the signal with best quality and share to wireless access points [50].

## 3. PROPOSED SYSTEM

### 3.1 System Design

In this paper, the [18] system was first implemented and simulated using Optisystem (14) to verify that it delivers the RF signal to 5000 Km and provides the wireless communication with given results successfully. After verification process has finished successfully with relative results, the main system parameters have been enhanced using trial and error technique, and it was discovered that after improving the main system parameters, the system length can be extended for 1000 Km more with BER of  $1.10 \times 10^{-55}$  and QF of 15.67 to increase the total distance from 5000 Km to 6000 Km. Later on, the system performance was further improved through using a Dispersion Compensation Fiber (DCF) before the system receiver to compensate the accumulated dispersion and further increase the system length. As a result, it was discovered that utilizing a DCF with length equal to 30 Km and Dispersion coefficient equal to  $-83.75$  ps/nm/Km have improved the system performance by decreasing the BER to  $1.00 \times 10^{-91}$  and increasing the QF to 20.27. After improving the transmission medium and obtaining better performance in term of BER and QF, the overall system length was increased from 6000 Km to 7000 Km. However, this increment in the system length has affected the performance at the receiver through increasing the BER to  $1.24 \times 10^{-25}$  and decreasing the QF to 10.39. As a result, it was decided to increase the DCF length

from 30 Km to 50 Km to be able to compensate the dispersion added during increasing overall system length. Nevertheless, this modification in the DCF length is insufficient to recompense the degradation occurred in the signal during extending the system length. Therefore, to compensate the additional dispersion, mitigate the noise and magnify the original signal, a DCF of 50 Km, an FBG at 1300 nm of wavelength and OA with 20 dB of gain have been added before the receiver respectively. This change has decreased the BER to  $3.34 \times 10^{-56}$  and increased the QF to 15.74.

### 3.2 Simulation Design

The proposed RoF system was made using Optisystem 14, which is one of the advanced versions of Optiwave Company that includes various novel technologies and provides more realistic results as compared to previous versions since it contributes almost all the linear and non-linear effects [51, 52]. As a result, the final simulation design of the proposed RoF system after all improvements and parametric enhancements in term of components and blocks is represented in Fig. 4.

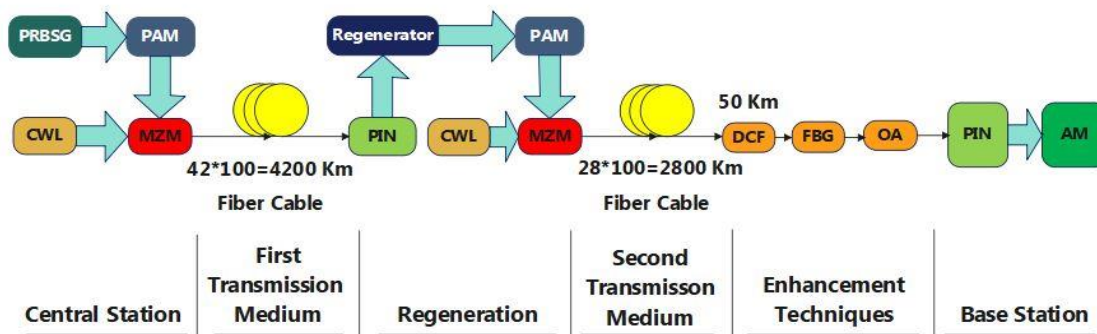

Fig. (4):-Final Block Diagram of the Proposed System.

From simulation design, it is clear that the system is classified into different main stages. These stages include transmitter stage or CS, 4200 Km of fiber length as first transmission medium, regenerator stage, 2800 Km of fiber cable as second transmission medium, transmission medium enhancement techniques stage, receiver stage, and Wireless Distribution stage. As any other RoF systems, the first stage of the Proposed system is also CS that generates 2 Gbps data rate electrical baseband signal from PRBSG and PAM with 1 Bps. Then, the resultant signal is modulated over a CWL with a power of 7.5 dBm and Line Width (LW) of 0.2 MHz on 1300 nm wavelength using an external Mach Zehnder Modulator (MZM) having an Extinction Ratio (ER) of 22.918 dB to generate a compact optical signal. The second stage of this system is first transmission medium that provides the transmission of the generated optical signal for 4200 Km of distance with lowest possible attenuation through utilizing 42 SMF of 100 Km along with OAs of 20 dB gain and 4 dB Noise Figure (NF). The third stage of the proposed system has become the signal regeneration stage to regenerate the original signal and reduce the

attenuation effect to be transmitted for farther 2800 Km. Despite of that the regenerator circuit will increase the overall system cost, it successfully delivers the 2 Gb/s RF signal to 7000 Km with perfect BER and QF. In order to regenerate the original signal, the proposed system demodulates the optical signal using Positive-Intrinsic-Negative (PIN) Photodetector and removes the noise using Low Pass Bessel Filter (LPBF) with wavelength of 1300 nm to reproduce the RF signal. The resultant electrical signal is then resampled using M-ary threshold Detector operating with 3 mW and 7 mW such that, if the power of the attenuated signal was less than 3 mW, then it would decide that the message was -1, while if the power of the attenuated signal was greater than 7 mW, then it would decide that the message was +1 and otherwise it would detect the value to be 0. After that the generated binary message from detector would be decoded and re-encode using PAM decoder and encoder.

Finally, the resultant baseband signal is modulated over another CWL with power of 9.27 dBm through another MZM with ER of 12 to be transmitted across remaining 2800 Km of fiber length as second transmission medium. Similarly,

as the second stage, the fourth stage of this system is second transmission medium that provides the transmission of the regenerated optical signal for 2800 Km of distance. The fifth stage of this system is transmission medium enhancement technique that is utilized to compensate the dispersion resulted from accumulated transmission length, filter the received signal through attenuating noise signal and passing the required signal and amplify it to be read easily by the system receiver. In the proposed system DCF of 50 Km length is utilized to compensate the available dispersion, FBG device is used as frequency reflector to transmit signals on 1300 nm of wavelength and reflect all other frequencies and OA is utilized to amplify the attenuated signal using 20 dB of gain and 4 NF. These enhancement techniques are used in the proposed system to enhance the transmission length from 6000 Km to 7000 Km. The sixth stage of the proposed system is the receiver stage or BS that receives the transmitted optical signal, converts it to electrical form, and prepares it for RF distribution in the next stage (Wireless Communication Stage). In this stage, a PIN photodetector with dark current of 5 nA and the thermal noise co-efficient of  $100 \times 10^{24}$  WpHz is utilized to demodulate the optical signal. The resultant noisy signal is filtered using LPBF to remove the available noise and prepares it for wireless distribution with BER of  $3.34 \times 10^{-56}$  and QF of 15.74. However, to share an original like signal, the proposed system regenerates the signal using similar components utilized in the regeneration stage, which are M-ary threshold detector that operates on 1 and 2 mW of power to convert the electrical pulses into binary code and PAM encoder and decoder to encode and decode the resultant binary code. The final stage of this system is wireless distribution that distributes the RF signal received after 7000 Km of distance through utilizing 2 electrical AM modulators with frequency of 2.4 GHz SMF. As a result, the simulation has been performed to consider the effects of parametric value modification and adding transmission medium enhancement techniques on the system performance in various scenarios.

#### 4. Simulation Results

At the beginning, all the system parameters from Central Station (CS) to Base Station (BS) were enhanced to find if modification in the parametric values can improve the overall system

performance. From the transmitter stage, it was found that the power of the Continuous Wave Laser (CWL) and Extinction Ratio (ER) of the MZM are the most effective parameters that can affect the system performance. Therefore, power of the CWL was examined from 0 to 10 dBm to find the highest system performance in term of BER and QF. The results have showed that the BER was 1 and QF was 0 for power below 7 dBm, which means that the system cannot operate with a CWL power lower than 7 dBm. However, for power greater than 7 dBm, the system performance was providing an acceptable result in term of BER and QF. In addition, the optimum performance was found when the CWL power was equal to 8 dBm with minimum BER equal to  $7.70 \times 10^{-27}$  and maximum QF equal to 10.66. Therefore, the CWL power was examined from 7 dBm to 10 dBm with a step of 0.3 and the best system performance was found when the power was 7.6 dBm with a BER of  $3.74 \times 10^{-28}$  and QF of 10.938. The second effective parameter in the transmitter stage was ER of the MZM. Therefore, it was examined from 20-40 and the best system performance was found when the ER was 23 with a BER of  $3.74 \times 10^{-28}$  and QF of 10.938. Since this RoF system consists of a regeneration stage that include another CWL and MZM, the other two effective parameters were the power of CWL and ER of MZM in this stage. Thus, the ER of the regenerating MZM was examined from 5-25 and the results have showed the best system performance when the ER was 11 with a BER equal to  $2.79 \times 10^{-53}$  and QF equal to 15.30. In order to detect the best ER value, it was observed from 9-15 with a step of 0.5 and the results have shown that the best BER of  $8.88 \times 10^{-56}$  and QF of 15.68 was found at ER equal to 12.5. While for regenerating CWL, the power was observed from 0 to 15 dBm and the best system performance with a BER of  $8.06 \times 10^{-62}$  and QF of 16.54 was found when the input power was 9 dBm. After improving the system performance by tuning the system parameters from a BER of  $4 \times 10^{-37}$  and QF of 12.6667 of the previous system into a BER of  $8.06 \times 10^{-62}$  and QF of 16.54 of the proposed system, the system length was extended to 18 iterations (3600 Km) for the first loop and 12 iterations (2400 Km) for the second loop that makes a total of 30 loops (6000 Km) with best performance having a BER of  $1.10 \times 10^{-55}$  and QF of 15.67 as shown in Fig. 5.

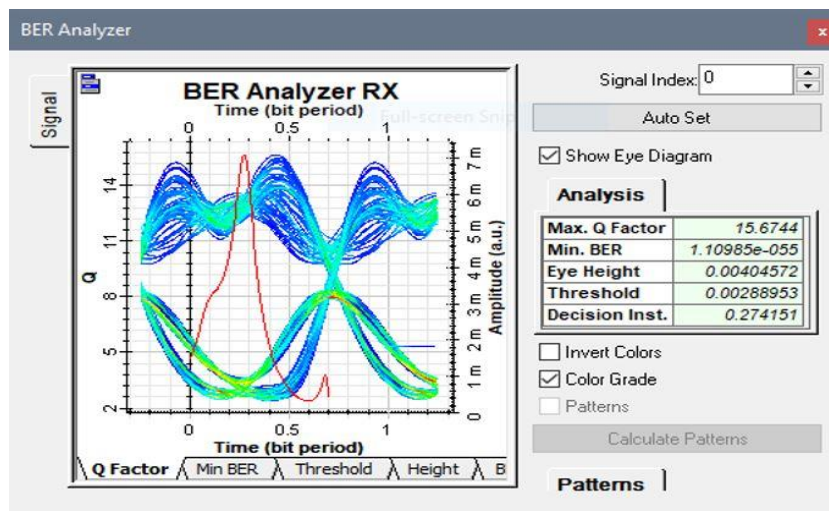

Fig.( 5 ):- BER Analyzer After 6000 Km.

Following the abovementioned parametric enhancement and system length extension, several transmission medium enhancement devices were utilized to further improve the system length. These enhancements components include Dispersion Compensation Fiber (DCF) to compensate the available dispersion, Fiber Bragg Grating (FBG) to reflect the undesired frequency

and transmit the desired frequency and an OA to amplify the attenuated signal. As a result, by adding a DCF with 30 km length before the receiver the system performance has been enhanced from a BER of  $1.10 \times 10^{-55}$  and QF of 15.67 to a BER of  $1.00 \times 10^{-91}$  and QF of 20.27 as shown in Fig. 6.

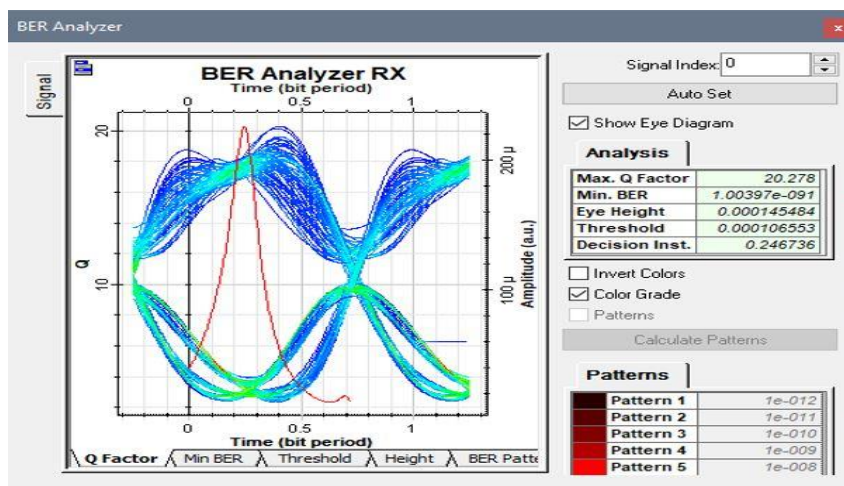

Fig. ( 6 ):-BER Analyzer after Adding a 30 Km length DCF before the Receiver.

Following that the system length was improved to 21 iterations (4200 Km) for the first loop and 14 iterations (2800 Km) for the second loop that makes a total of 35 loops (7000 Km) with the best performance having a BER equal to

$1.24 \times 10^{-25}$  and QF equal to 10.39, However, due to the accumulated dispersion added through system length extension, the system performance has decreased remarkably as shown in Fig. 7.

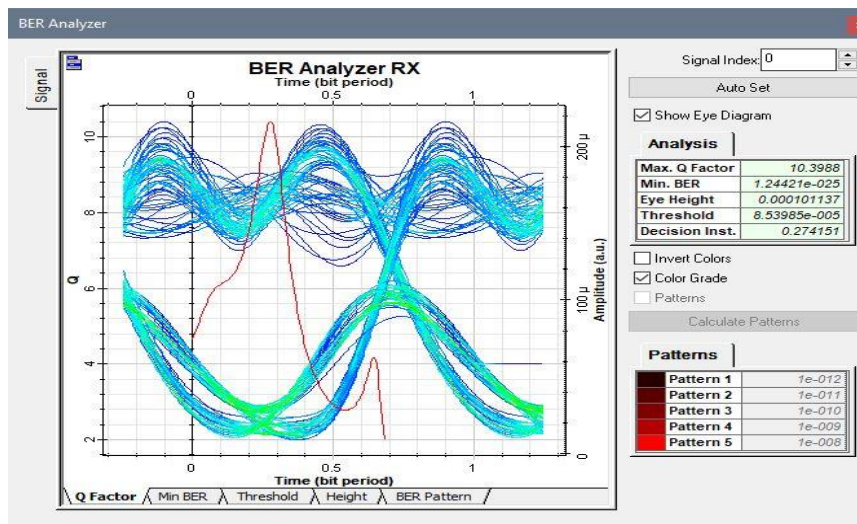

Fig.( 7):- BER Analyzer After 7000 Km.

In order to mitigate this dispersion and enhance the system performance, the length of DCF is increased to 50 km with the best performance having a BER equal to  $4.63 \times 10^{-36}$  and QF equal to 12.48 as shown in Fig. 8. After improving the system length to 7000 with acceptable performance, the signal quality was further improved through adding an FBG and an

OA after the DCF position. In which the FBG with an operation frequency of 1300 nm has increased the system performance to have a BER of  $7.66 \times 10^{-44}$  and QF of 13.83, as shown in Fig. 9. However, by adding an OA with a gain of 20 dB and NF of 4 dB the system performance was enhanced to have a BER equal to  $3.34 \times 10^{-56}$  and QF equal to 15.74 as shown in Fig.10.

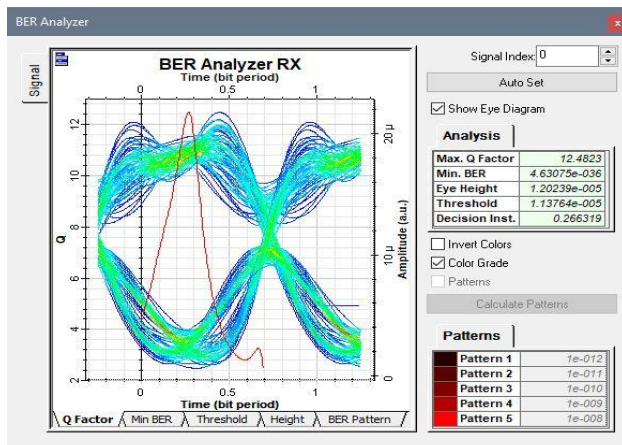

Fig. (8):- BER Analyzer after Ext ending the DCF length to 50 Km

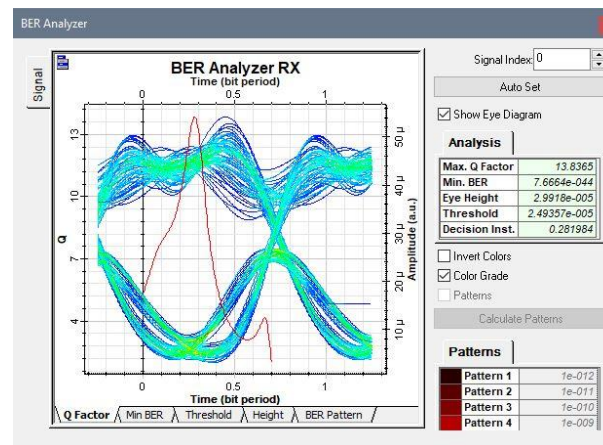

Fig.( 9):- BER after Adding an FBG with 1300 nm.

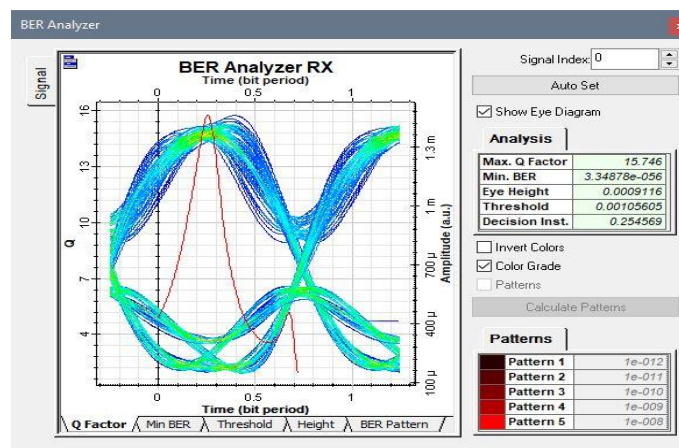

Fig. (10):- BER Analyzer after Adding OA with gain of 20 dB.

In order to summarize this section, Table 1 presents the system performance in term of BER and QF in eight stages, to clarify the effect of the

modifications and enhancements on the system performance before and after each stage.

Table (1):-System Performance in term of BER and QF in Each Stage.

Parameter	Trial and Error	Optimization (BER)	Optimization (QF)	Final
CS Power	7.6 (dBm)	7.5 (dBm)	7.5 (dBm)	7.5 (dBm)
CS MZM ER	23 (dB)	23 (dB)	22.918 (dB)	22.918 (dB)
RG Power	9 (dBm)	10 (dBm)	9.27 (dBm)	9.27 (dBm)
RG MZM ER	12 (dB)	12 (dB)	12 (dB)	12 (dB)
DCF Length	50 (Km)	50 (Km)	50 (Km)	50 (Km)
OA Gain	20 (dB)	20 (dB)	20 (dB)	20 (dB)

After enhancing the overall system length from 5000 Km to 7000 Km successfully, an Optisystem toolbox known as Optimization was used to verify that the selected parametric values using trial and error technique are the best values. Optimization is an Optisystem tool used to find the optimum parametric value for each component of the system in several manners, such as Single Parameter Optimization (SPO), Multiple Parameter Optimization (MPO), Monte

Carlo Yield Estimation (MCYE), etc. In addition, the algorithm utilized in this technique is called Least Square Algorithm (LSA).

Table 2 illustrates the difference between the parametric value for the 6 main and effective system parameters estimated through trial and error and optimization method to determine the final value for each parameter utilized in the enhanced system and obtain the best system performance.

**Table( 2 ):-**Illustration of the Parametric Value Selected using Trial and Error Method and Optimization Method

System performance in Different Stages	BER	QF
Before any Enhancements	$4.33 \times 10^{-37}$	12.6667
After Parametric Enhancement Using Trial and Error Method	$8.06 \times 10^{-62}$	16.54
After Increasing System Length to 6000 Km	$1.10 \times 10^{-55}$	15.67
After adding DCF of 30 Km Length	$1.02 \times 10^{-91}$	20.27
After Increasing System Length to 7000 Km	$1.24 \times 10^{-25}$	10.39
After Increasing DCF Length to 50 Km	$4.63 \times 10^{-36}$	12.48
After adding FBG	$7.66 \times 10^{-44}$	13.83
After adding OA	$3.34 \times 10^{-56}$	15.74

In order to discover the effect of the improvements applied on the [18], the RoF system and evaluate the performance of the proposed system, a comparison is made between the main simulation results of both RoF systems. As a result, an optical spectrum analyzer was used to show the optical spectrum at the output of CS for both systems and it was found that the CS of both systems have an acceptable performance and they have peak power value at 1300 nm. However, due to the CWL power modifications, the [18] system was generating an optical signal with maximum and minimum power of 11.42 and -105.30 dBm Respectively . While the proposed system was generating a signal with maximum

power of 8.34 dBm and minimum power of -105.15 dBm. However, to confirm that the optical signal was received successfully, a BER analyzer was utilized at the receiver stage to illustrate the eye diagram and assess the performance of both systems in term of BER and QF. As a result, the received signal of the [18] system had an acceptable eye opening with BER of  $4.33 \times 10^{-37}$  and QF of 12.6667, as shown in Fig. 11, While the received signal of the Proposed system had a better eye opening with BER of  $3.34 \times 10^{-56}$  and QF of 15.74 even with additional 2000 Km, as shown in Fig. 12.

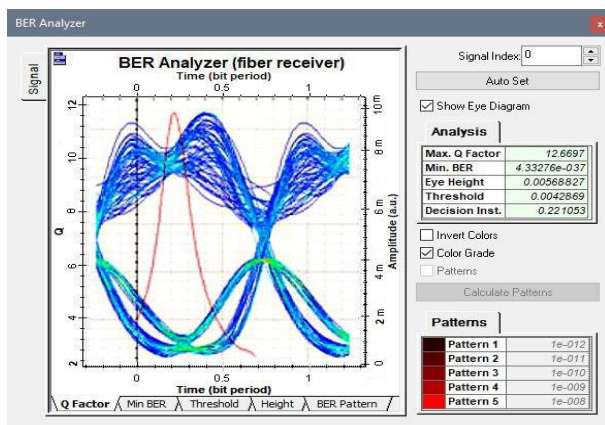

**Fig.( 1 ):-** BER Analyzer at the Receiver of the [18] System.

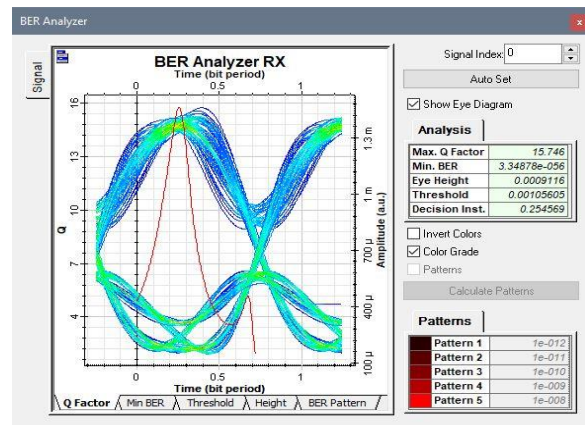

**Fig.( 2 ):-** BER Analyzer at the Receiver of the Proposed System.

Finally, in order to verify that the transmitted message signal of the proposed system is received to the receiver stage successfully, the oscilloscope visualizer of the PAM at the transmitter stage was compared to the oscilloscope visualizer of the PAM at the receiver stage, as shown in Fig. 13.

The results have clearly showed that for the 10 bits of the beginning of the message the result was the same at both ends and this was applied to several other bits and the results successfully matched.

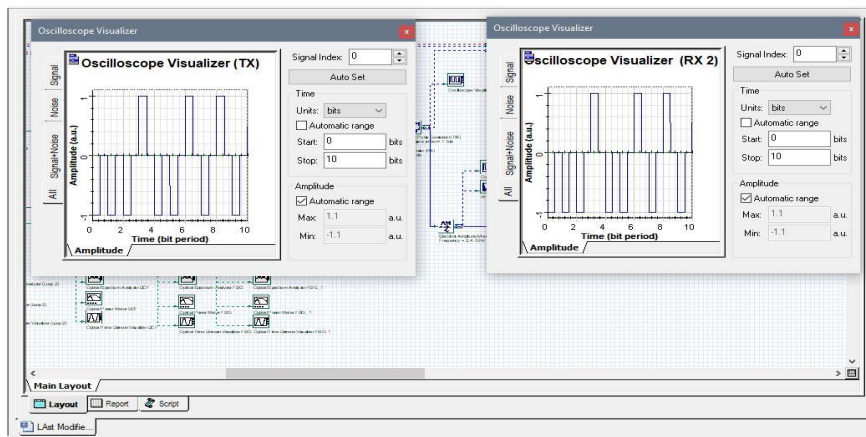

**Fig. ( 3):-** Comparison Between the TX and RX Message signal of the Proposed System.

In order to summarize this section and visualize the effect of enhancements made in this work on the system performance, Table 3

provides a comparison between both systems in term of transmission power, receiving power, QF, and BER.

**Table ( 3):-** Comparison Between the Final Simulation Results of the [18] system and Proposed system.

parameter	CWL Power at the CS (dBm)	Actual power at the CS (dBm)	Power at the RX (dBm)	Distance (Km)	QF	BER
(Abdullah et al., 2019) System	10	6.958	9.02 and -87.02	5000	12.667	$4.33 \times 10^{-37}$
Proposed System	7.5	4.388	7.71 and -105.12	7000	15.74	$3.34 \times 10^{-56}$

## 5. CONCLUSION

Recently, the Radio over Fiber (RoF) technology has become the area of research since it is utilized in mobile telecommunications to fulfill the huge demand of today's wireless communication subscriber, such as high bandwidth and high data rate. In this paper, a comprehensive review has been made on RoF systems and its main stages to understand the working principles and the design of the system and provide the wireless communication at large distances. After that, the performance of a RoF system for long distance communication has been improved through tuning the main system parameters and using several transmission medium enhancement techniques to provide the wireless communication at larger distances with higher signal quality. This improvement includes extending the overall system length by a range of 40% from 5000 Km to 7000 Km along with

decreasing the BER by a range of 51.35% from  $4.33 \times 10^{-37}$  to  $3.34 \times 10^{-56}$  and increasing the QF by a range of 24.26% from 12.6667 to 15.74.

## REFERENCES

- C. Lim, Y. Tian, C. Ranaweera, T. A. Nirmalathas, E. Wong, and K.-L. Lee, "Evolution of radio-over-fiber technology," *Journal of Lightwave Technology*, vol. 37, no. 6, pp. 1647-1656, 2019.
- S. Addanki, I. S. Amiri, and P. Yupapin, "Review of optical fibers-introduction and applications in fiber lasers," *Results in Physics*, vol. 10, pp. 743-750, 2018.
- A. Goldsmith, *Wireless communications*. Cambridge university press, 2005.
- A. A. Hussien and A. H. Ali, "Comprehensive investigation of coherent optical OFDM-RoF employing 16QAM external modulation for long-haul optical

- communication system," *International Journal Electrical and Computer Engineering (IJECE)*, vol. 10, no. 3, pp. 2607-2616, 2020.
- D. Mohsen, A. Hammadi, and A. Alaskary, "Design and Implementation of 1.28 Tbps DWDM based RoF system with External Modulation and Dispersion Compensation Fiber," in *Journal of Physics: Conference Series*, 2021, vol. 1963, no. 1, p. 012026: IOP Publishing.
- S. Kumar, S. Sharma, and S. Dahiya, "WDM-Based 160 Gbps Radio Over Fiber System With the Application of Dispersion Compensation Fiber and Fiber Bragg Grating," *Frontiers in Physics*, vol. 9, p. 235, 2021.
- A. F. Molisch, *Wireless communications*. John Wiley & Sons, 2012.
- A. Zin, M. Bongsu, S. Idrus, and N. Zulkifli, "An overview of radio-over-fiber network technology," in *International Conference On Photonics 2010*, 2010, pp. 1-3: IEEE.
- A. K. Vyas and N. Agrawal, "Radio over fiber: Future technology of communication," *International Journal of Emerging Trends & technology in computer science (IJETTCS)*, vol. 1, no. 2, pp. 233-237, 2012.
- H. Khalil *et al.*, "Performance Analysis of Modulation Formats for Next Generation RoF Systems," *IEEE Access*, vol. 9, pp. 139393-139402, 2021.
- A. Sharma, S. Chaudhary, D. Thakur, and V. Dhasratan, "A cost-effective high-speed radio over fibre system for millimeter wave applications," *Journal of Optical Communications*, vol. 41, no. 2, pp. 177-180, 2020.
- A. O. Aldhaibani, S. Yaakob, R. Shaddad, S. Idrus, M. A. Kadir, and A. Mohammad, "2.5 Gb/s hybrid WDM/TDM PON using radio over fiber technique," *Optik-International Journal for Light and Electron Optics*, vol. 124, no. 18, pp. 3678-3681, 2013.
- I. A. Rather, G. Kumar, and R. Saha, "Survey on RoF technology and the mitigation schemes over the challenges in the RoF network," *Optik*, vol. 247, p. 168007, 2021.
- H. B. Kim, "Radio over fiber based network architecture," 2005.
- R. Singh, M. Ahlawat, and D. Sharma, "A review on radio over fiber communication system," *International Journal of Enhanced Research in Management & Computer Applications*, vol. 6, no. 4, pp. 23-29, 2017.
- K. K. Qureshi, A. R. Qureshi, M. G. Magam, and L. Jamal, "Radio-over-fiber front-haul link design using optisystem," *Journal of Optical Communications*, 2020.
- V. Sarup and A. Gupta, "A study of various trends and enabling technologies in radio over fiber (RoF) systems," *Optik*, vol. 126, no. 20, pp. 2606-2611, 2015.
- M. Abdullah, K. A. Omar, A. A. Qasim, A. M. Abdulrahman, and A. Dawood, "Radio over fiber (RoF) implementation using MZM for long distance communication," in *2019 international conference on information science and communication technology (ICISCT)*, 2019, pp. 1-6: IEEE.
- D. Opatić, "Radio over fiber technology for wireless access," 2009.
- A. H. Ali and A. D. Farhood, "Design and performance analysis of the WDM schemes for radio over fiber system with different fiber propagation losses," *Fibers*, vol. 7, no. 3, p. 19, 2019.
- A. Sharma and S. Rana, "Comprehensive study of radio over fiber with different modulation techniques—a review," *International Journal of Computer Applications*, vol. 170, no. 4, pp. 22-25, 2017.
- H. A. Mahmood and R. K. Ahmed, "Fiber bragg grating and channel spacing effect in WDM radio over fiber system using DPSK modulation format," *International Journal of Engineering & Technology*, vol. 7, no. 3.4, pp. 218-222, 2018.
- V. Jain and R. Bhatia, "Review on nonlinearity effect in radio over fiber system and its mitigation," *Journal of Optical Communications*, 2021.
- J. C. Prajapati and K. Maradia, "Performance Enhancement of Eight-Channel WDM-RoF-PON System at 80 Gbps Data Rate Using Raman Amplifier," in *Innovations in Electronics and Communication Engineering: Springer*, 2018, pp. 427-435.
- S. Asha, "A comprehensive review of Millimeter wave based radio over fiber for 5G front haul transmissions," *Indian Journal of*

- Science and Technology*, vol. 14, no. 1, pp. 86-100, 2021.
- N. Kathpal and A. K. Garg, "Analysis of radio over fiber system for mitigating four-wave mixing effect," *Digital Communications and Networks*, vol. 6, no. 1, pp. 115-122, 2020.
- A. A. Khadir, B. F. Dhahir, and X. Fu, "Achieving optical fiber communication experiments by optisystem," *International Journal of Computer Science and Mobile Computing*, vol. 3, no. 6, pp. 42-53, 2014.
- G. Nwafor, "No Referendum, No Election Campaign: How Radio Biafra Internet Broadcasting Mobilized IPOB Worldwide during the 2019 Nigerian Election," *The Journal of Society and Media*, vol. 6, no. 2, pp. 345-364, 2022.
- S. A. S. Saffar, "A REVIEW ON RADIO OVER FIBER SYSTEMS FOR LONG DISTANCE COMMUNICATION," *Academic Journal of Nawroz University*, vol. 11, no. 3, pp. 133-147, 2022.
- D.-T. Tran and N. T. Bui, "Improvements on the performance of subcarrier multiplexing/wavelength division multiplexing based radio over fiber system," *International Journal of Electrical and Computer Engineering*, vol. 11, no. 2, p. 1439, 2021.
- H. Kaur, M. S. Bhamrah, and B. Kaur, "A comprehensive study on radio over fiber systems: present evaluations and future challenges," *Journal of Optical Communications*, 2022.
- D. Tse and P. Viswanath, *Fundamentals of wireless communication*. Cambridge university press, 2005.
- B. J. Hamza *et al.*, "Performance Enhancement of SCM/WDM-RoF-XGPON System for Bidirectional Transmission With Square Root Module," *IEEE Access*, vol. 9, pp. 49487-49503, 2021.
- L. Chen *et al.*, "A novel scheme for seamless integration of ROF with centralized lightwave OFDM-WDM-PON system," *Journal of Lightwave Technology*, vol. 27, no. 14, pp. 2786-2791, 2009.
- F. Ali, F. Muhammad, U. Habib, Y. Khan, and M. Usman, "Modeling and minimization of FWM effects in DWDM-based long-haul optical communication systems," *Photonic Network Communications*, vol. 41, no. 1, pp. 36-46, 2021.
- M. Matsumoto, "Fiber-based all-optical signal regeneration," *IEEE Journal of Selected Topics in Quantum Electronics*, vol. 18, no. 2, pp. 738-752, 2011.
- D. Singh and P. Singh, "Techniques of millimeter-wave signal generation in RoF systems: A review," *International Journal of Computer Applications & Information Technology*, vol. 1, no. 2, 2012.
- R.-K. Shiu *et al.*, "A simplified radio-over-fiber system for over 100-km long-reach n-QAM transmission," *IEEE Photonics Journal*, vol. 12, no. 3, pp. 1-8, 2020.
- S. Rahman *et al.*, "Mitigation of nonlinear distortions for a 100 Gb/s radio-over-fiber-based WDM network," *Electronics*, vol. 9, no. 11, p. 1796, 2020.
- G. Kaur and R. Kaler, "Wavelength remodulation and dispersion compensation for full-duplex radio over fiber System using fiber Bragg grating," *Optik*, vol. 206, p. 163223, 2020.
- D. Kamissoko, J. He, H. Ganame, and M. Tall, "Performance investigation of W-band millimeter-wave radio-over-fiber system employing optical heterodyne generation and self-homodyne detection," *Optics Communications*, vol. 474, p. 126174, 2020.
- D. Jain and B. Iyer, "Design and Analysis of Single-Channel High-Speed RoF System Using Different Coding Techniques," *Available at SSRN 3656426*, 2020.
- M. Belkin, A. Alyoshin, and D. Fofanov, "Designing WDM-RoF Concept-Based Full-Duplex MMW Fiber Fronthaul Microcell Network," in *2020 26th Conference of Open Innovations Association (FRUCT)*, 2020, pp. 52-59: IEEE.
- D. Jain and B. Iyer, "Design and analysis of high-speed four-channel WDM Radio over Fiber system for Millimeter-wave applications," *International Journal of System Assurance Engineering and Management*, pp. 1-13, 2021.
- M. H. Raza, K. Zaidi, and S. Zaidi, "A review of full-duplex WDM RoF architectures," *Network Architectures, Management, and Applications V*, vol. 6784, pp. 732-742, 2007.

- I. Amiri, A. N. Z. Rashed, Z. Rahman, B. K. Paul, and K. Ahmed, "Conventional/phase shift dual drive Mach–Zehnder modulation measured type based radio over fiber systems," *Journal of Optical Communications*, 2020.
- V. Sudheer, R. Seena, and S. Sankararaman, "DPSK based low cost radio over fiber system for communication," *Optical and Quantum Electronics*, vol. 51, no. 5, pp. 1-7, 2019.
- C. H. Lee, V. Postoyalko, and T. O'Farrell, "Enhanced performance of RoF link for cellular mobile systems using postdistortion compensation," in *2004 IEEE 15th International Symposium on Personal, Indoor and Mobile Radio Communications (IEEE Cat. No. 04TH8754)*, 2004, vol. 4, pp. 2772-2776: IEEE.
- S. Chaudhary, P. Chauhan, and A. Sharma, "High speed  $4 \times 2.5$  Gbps-5 GHz AMI-WDM-RoF transmission system for WLANs," *Journal of Optical Communications*, vol. 40, no. 3, pp. 285-288, 2019.
- B. Ait Ahmed, O. Aghzout, M. Chakkour, F. Chaoui, and A. Naghar, "Transmission performance analysis of WDM radio over fiber technology for next generation Long-Haul optical networks," *International Journal of Optics*, vol. 2019, 2019.
- M. Z. Jamaludin and F. Abdullah, "OptiSystem: an alternative to optoelectronics and fiber optics teaching e-laboratory," *International Journal of Asian Social Science*, vol. 4, no. 2, pp. 307-313, 2014.
- I. Kaminow, T. Li, and A. E. Willner, *Optical fiber telecommunications VB: systems and networks*. Elsevier, 2010.