

PERFORMANCE IMPROVEMENT OF BER BASED ON MULTIPATH FORWARD ERROR CORRECTION DIVERSITY IN WIRELESS COMMUNICATION CHANNELS

AHMAD BAHEEJ AL-KHALIL

Dept. of Computer Science, College of Science, University of Duhok, Kurdistan Region, Iraq

(Received: April 28, 2020; Accepted for Publication: June 14, 2020)

ABSTRACT

The multipath phenomenon is a major factor that is continually affected negatively the performance of wireless communication systems. Since the receiver gets different copies of the transmitted signal from various paths at different times. Consequently, destructive or constructive interference can occur. Therefore, the performance of wireless communication systems is poor in term of bit error rate. This phenomenon can be taken as an advantage if the multiple – input – multiple – output antenna systems are employed at both transmitter and receiver sides (antenna diversity) to improve the bit error rate performance. This paper focuses on the combination of multipath forward error correction diversity technique with vertical-Bell laboratories layered space-time coding. This will lead to enhance the bit error rate in wireless communication systems. The proposed system used Rayleigh and additive white Gaussian noise as two different channel models. The multipath forward error correction diversity technique treats the multipath propagated signals as unessential copies, to utilise them to enhance the bit error rate limitation in the multiple – input – multiple – output systems. The simulation results showed that the performance of the proposed system can be gradually improved by increasing the number of utilised multipath signals in the multipath forward error correction diversity technique.

KEY WORDS: FEC, Diversity, BER, Multipath, CWMC, MIMO, V-BLAST, Rayleigh, AWGN.

1. INTRODUCTION

At present, there is a noticeable achievement in the development of wireless communication systems field. This development requires more efforts to provide high communication reliability and improving the data rate (Seferagić et al. 2020). Subsequently, challenges in the industry of communication are presented especially in enhancing the performance of the wireless communication system in term of quantity and quality (Farzamnia et al. 2019).

In wireless communication, the transmitted signals propagate via a wireless channel. These signals can face a certain level of fading such as shadowing, diffraction, reflection and noise. Furthermore, the recipient will get a direct copy (the original copy) of the transmitted signal Line – of – Sight (LoS) path in addition to the other copies that arrived from different paths Non – Line – of – Sight (NLoS) at a slightly different time (Jakborvornphan 2019). As a result, a signal distortion or disruption and errors will have occurred, and the original signal cannot be retrieved at the receiver.

Diversity is one of the approaches used to combat the effect of fading in wireless communication systems (Khatoon and Chidar 2019). Diversity is a powerful and effective technique which can overcome the multipath fading channel effect and avoiding error bursts (O. A et al. 2014). The idea of the diversity techniques is to provide the receiver by uncorrelated faded replicas of LoS signal. After that, two or more copies of the received signal are combined to raise the overall Signal – to – Noise – Ratio (SNR). Diversity can be produced and represented by several ways such as space diversity, time diversity, frequency diversity, polarisation diversity and angle diversity. Moreover, different diversity techniques can be combined to enhance the reliability and the performance of the wireless communication systems (Anbarasi et al. 2017). For instance, antenna diversity can be concatenated with time diversity that can be obtained by channel coding.

This paper is structured as follows: section (2) covers the related work, while the principles of diversity is explained in section (3). Section (4) demonstrates the proposed diversity method. While section (5) presents the research

methodology. Section (6) discuss the obtained results and finally, section (7) is the conclusion.

2. RELATED WORK

The multipath error correction scheme was used to estimate each channel's multipath profile in the process of the mitigation of multipath phenomena in the radio interferometric positioning system (Cheng Zhang et al. 2017). Authors proposed the scheme of multipath error correction based on phase and amplitude of the received signal. As a result, the estimated errors during the transmission can be reduced significantly under both moderate and severe multipath conditions (Cheng Zhang et al. 2017).

The effects of multipath on the vehicular networks video streaming has also attracted the attention of researchers. In (Aliyu et al. 2018), the authors were concentrated on the use of FEC as a link quality parameter for multipath video streaming to minimize route coupling effect. They implemented a simulation study upon numerical formulations to show the presence of a vehicle within the network as an angle area. Their results showed that FEC in their proposed simulation was able to improve the quality of video streaming (Aliyu et al. 2018). In the same context, the author of (Herrero 2017) presented a mathematical model for the playback of media in real-time communications under multipath conditions. The author utilized both real-time protocol (RTP) and FEC. Within this engagement, the proposed model could achieve reliable communications (Herrero 2017).

The FEC can lower the loss at a cost of increased throughput of the application layer in a wireless environment (Herrero and Hernandez 2019). Increased throughput is a characteristic of FEC that can play a major role in improving real-time communication (RTC). The researchers in (Herrero and Hernandez 2019) recommended to investigate the using of more efficient higher rate block codes and the data redundancy of WSN can be explored utilizing alternative mechanisms to improve the FEC. Moreover, the combination of FEC with other techniques can show more improvements in multipath environments. (Agarwal and Mehta 2018) presented an extensive study in which they ran a survey that covered concatenated FEC techniques as efficient approaches. The outcomes of their survey showed that BER improvement in the multipath environment can be achieved by a combination of FEC techniques and space-time code (STC)

(Agarwal and Mehta 2018). Furthermore, they demonstrated that the MIMO-OFDM system can be considered as one of the most powerful diversity techniques to support high data rate in fading channel conditions.

Rely on the length of transmission between the components of multipath and the delay of propagation, a multipath FEC diversity technique is found (Bae et al. 2015). The multipath FEC diversity technique is utilized to enhance the performance of Bose Chaudhuri Hocquenghem (BCH) and Reed Solomon (RS) codes using Single- Input Single- Output (SISO) system (Al-Barrak et al. 2017). Besides, in another approach, the authors of (Al-Khalil and Al-Barrak 2018) employed the multipath FEC diversity technique using MIMO systems to improve the performance of BCH and RS codes over the Alamouti code. The multipath FEC could show enhancement in BCH and RS codes without increasing the number of redundancies.

All the techniques and the results that been utilized based on multipath FEC showed a positive improvement in the performance of the wireless communication systems. This encourages to thinking about the outcome of implementing the multipath FEC technique in other wireless communications systems such as V-BLAST MIMO over Rayleigh channel and AWGN channel. Therefore, this paper aims to investigate and analyse the multipath FEC diversity technique effectiveness on the performance of V-BLAST MIMO wireless communication systems.

3. THE PRINCIPLES OF DIVERSITY

Diversity techniques represent an approach to minimise the multipath effect and improve the performance of the wireless system by supplying multiple copies of the same information or the transmitted signal to the receiver. Diversity combination principles have been known since 1927 when the first experiments were reported (Jakes 1974). In Diversity technique, many copies of the required signal are produced by employing several channels. The concept behind this is that some of the copies might undergo deep fading, while others may not (Keith Q. T. Zhang 2015). In this case, the receiver may be still capable of obtaining enough information to recover the transmitted signal.

In wireless communication, three domains are used: space, frequency and time. Accordingly, these three resources can introduce space,

frequency and time diversity. Each diversity type has a particular condition which must be met to provide uncorrelated fading channels (Cai et al. 2016). There are several diverse techniques for different domains that are utilised in wireless communication systems. In practice, multiple diversity techniques are usually used together. Table 1 shows different diverse techniques and their advantages and disadvantages.

Table (1): Diversity Techniques and Their Advantages and Disadvantages

Diversity Technique	Pros	Cons
Antenna/Space Technique	<ul style="list-style-type: none"> • Simple to design. No requirement to increase the bandwidth nor power. • Any order of diversity is achievable. 	<ul style="list-style-type: none"> • The size of the hardware could be large and relies on device technologies. • Large separation is necessary at transmit and receive antennas.
Frequency Technique	<ul style="list-style-type: none"> • Any diversity order is achievable. 	<ul style="list-style-type: none"> • To achieve diversity of order L, L times more spectrum and power are required.
Angle Technique	<ul style="list-style-type: none"> • Doppler spread is reducible. 	<ul style="list-style-type: none"> • The gain of diversity relies on the obstacles around the receiving antenna. • Can be applied at the receiver side only.
Polarisation Technique	<ul style="list-style-type: none"> • No space is required. • No bandwidth raise is needed. 	<ul style="list-style-type: none"> • Provides only order two diversity. • Requires extra three decibels power.
Time Technique	<ul style="list-style-type: none"> • No space is required. • Provides any diversity order. • Hardware is quite simple. 	<ul style="list-style-type: none"> • To achieve diversity of order L, L times more spectrum is required. • When f_d is small, large buffer memory is needed

To achieve diversity gain, the copies from the different paths must be processed intelligently to raise the overall received SNR (Uzma et al. 2019). All the received replicas should undergo uncorrelated fading. Diversity processing can be accomplished before or after the detection stage

(Kumar 2015). There are four diversity processing techniques based on the selection or combining scheme that is used to deal with the received signals: switching, selection, Maximum Ratio Combining (MRC) and Equal-Gain Combining (EGC) diversities techniques (Milic et al. 2019).

4. THE PROPOSED DIVERSITY METHOD

A. Multipath FEC Diversity Technique

The obstacles that are present in the wireless communication environment can mainly cause the multipath propagation phenomenon (Jakborvornphan 2019). The transmitted signal that deploys via a wireless channel can be faded due to different circumstances such as reflection, scattering, diffraction and refraction. However, multiple copies of the transmitted signal will arrive at the receiver side via different paths at different times besides the original LoS signal. In this work, the proposed system is designed based on the utilisation of multipath FEC diversity technique to treat some of the NLoS signals as redundant copies. These redundant copies will be used to enhance the Bit Error Rate (BER) limitation in the MIMO systems which help in saving the channel resource and decrease the channel overhead. Since the identical signals differ slightly in their arrival time and propagation delay, the recipient can break up and receive more than two copies from the transmitter according to the following condition (Al-Barrak et al. 2017):

$$\frac{\text{Speed of Light}}{\text{Chip Rate}} \rightarrow \frac{3.0 \times 10^8 \text{ms}^{-1}}{\text{Chip Rate}} \leq TL, \quad (1)$$

$$\tau = \frac{TL}{\text{Speed of Light}} = \frac{TL}{3.0 \times 10^8 \text{ms}^{-1}} \quad (2)$$

Where

TL : Minimum transmission length.

τ : Delay time.

For instance, if the chip rate is 1.28 Mcps, then TL will be at less 234 m, and the chip duration or multipath delay τ is equal to 0.78 μs , which is fair enough to get more than one replica from the received multipath components. As one of the goals of this work is to improve the data transmission rate of the wireless communication systems, therefore, these copies will be treated as redundant replicas of the desired signal and will be employed to raise the performance of BRE limit.

B. Column Weight Multipath Combiner

The Column Weight Multipath Combiner (CWMC) is a diversity processing technique proposed in 2016 (Al-Barrak et al. 2016). In this technique, the Hamming weight is employed to combine LoS and NLoS signals in one signal. The combiner receives L copies from one transmitted signal as an input, where L should be an odd number and include LoS signal. The received signals are arranged in $L \times N$ matrix:

$$M_C = \begin{bmatrix} c_{11} & c_{12} & \dots & c_{1N} \\ c_{21} & c_{22} & \dots & c_{2N} \\ c_{31} & c_{32} & \dots & c_{3N} \\ \dots & \dots & \ddots & \vdots \\ c_{L1} & c_{L2} & \dots & c_{LN} \end{bmatrix}$$

The output signal Z is.

$$Z = [z_1, z_2, z_3, \dots, z_N]$$

Where z_i is.

$$z_i = \begin{cases} 0 & \text{if } w_{h_i} < \frac{L+1}{2} \\ 1 & \text{if } w_{h_i} \geq \frac{L+1}{2} \end{cases} \quad (3)$$

and w_{h_i} is:

$$w_{h_i} = \sum_{j=1}^L c_{ji}$$

Where

$$i = 1 - \text{to} - L.$$

$$j = 1 - \text{to} - N.$$

y_{ij} : The combiner output.

This example illustrates the use of column weight multipath combiner. The example considers that a LoS copy and four NLoS different copies of the transmitted signal have been received (C1, C2, C3, C4 and C5) where $L = 5$, and each received signal has four-bit long $N = 4$:

- C1 = [1101],
- C2 = [0111],
- C3 = [1000],
- C4 = [0111], and
- C5 = [0000]

The matrix will be:

$$M_C = \begin{bmatrix} 1 & 1 & 0 & 1 \\ 0 & 1 & 1 & 1 \\ 1 & 0 & 0 & 0 \\ 0 & 1 & 1 & 1 \\ 0 & 0 & 0 & 0 \end{bmatrix}$$

The received signal will be:

$$Z = [0,1,0,1]$$

5. RESEARCH METHODOLOGY

The block diagram in Figure (1) illustrates the multipath propagation for the Vertical-Bell Laboratories Layered Space-Time (V-BLAST) MIMO wireless systems. The transmitted signal propagates via two, four, or eight antennas. The random integer block generator is used to produce a random sequence of 0's and 1's for N bits (Figure 1). The generated sequence will be modulated into a waveform signal by the modulation block. During the modulation process, four different modulation schemes are employed: Binary Phase Shift Keying (BPSK), 4, 16 and 64 Quadrature Amplitude Modulations (QAMs). As the signal wirelessly travels, the noise plays a major role by influencing the transmitted signal. Therefore, the function of the channel block is adding AWGN noises to the modulated signal. In addition, the channel block is also used to generate V NLoS paths alongside to LoS signal. The effect of the actual properties of the signal is analysed and studied by using the channel block.

The receiver also uses two, four or eight antennas to get the transmitted LoS and V NLoS signals. In this stage, the LoS and NLoS signals will be chosen according to their threshold which is used to determine the minimum value of the accepted SNR. The NLoS signals can be considered as LoS copies if their SNR is \geq the threshold. The threshold value relies on the SNR of LoS, and it can be any value between 40% - 75% from LoS SNR. Hence, this stage is represented in the block (Select L Signal) as shown in Figure 1.

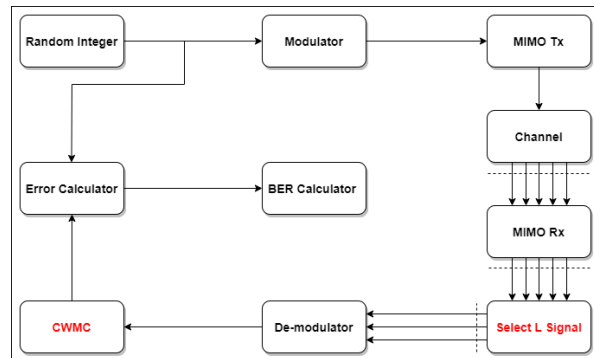

Fig. 1: Multipath Propagation for V-BLAST MIMO System

6. SIMULATION RESULTS

In this work, the simulation results run upon two scenarios. In the first scenario, the proposed diversity performed under the Rayleigh channel model, while the second scenario considered Additive White Gaussian Noise (AWGN) as a channel model. Table (2) shows the simulation environment setting for the proposed diversity. Table (2) shows the simulation environment setting for the proposed diversity.

Table (2): Simulation Environment Setting

Number of Antennas	Modulation Scheme	Channel Modelling
MIMO 2x2	BPSK	Rayleigh
MIMO 4x4	4QAM	AWGN
MIMO 8x8	16QAM 64QAM	

Figures 2, 3 and 4 reveal the simulation results under the *Rayleigh channel*. The main objective of these tests is the evaluation of the BER performance for the proposed diversity and diversity process.

The obtained results showed a significant performance improvement in the BER for the all three V-BLAST MIMO (2x2, 4x4 and 8x8) systems. The reason behind this improvement is the employment of two, four, six and eight multipath signals in addition to the main signal, and combining them with the CVMC combiner.

In Figures 2b, 3b and 4b, the minimum number of multipath signals (two signals) have been utilised under the 4QAM modulation scheme. The results showed that the BER performance is enhanced nearly by 3dB, 5dB and 7dB for MIMO 2x2, MIMO 4x4 and MIMO 8x8 systems respectively at 10^{-3} BER. However, increasing the number of multipath copies to four signals have boosted the improvement more.

The enhancement of the MIMO 2x2, MIMO 4x4 and MIMO 8x8 systems are raised approximately by 1dB, 2dB and 3dB respectively at the same BER value. It has been observed that the improvement of the BER performance of the MIMO 8x8 systems is better than the BER performance of MIMO 2x2 and MIMO 4x4 systems under the Rayleigh channel.

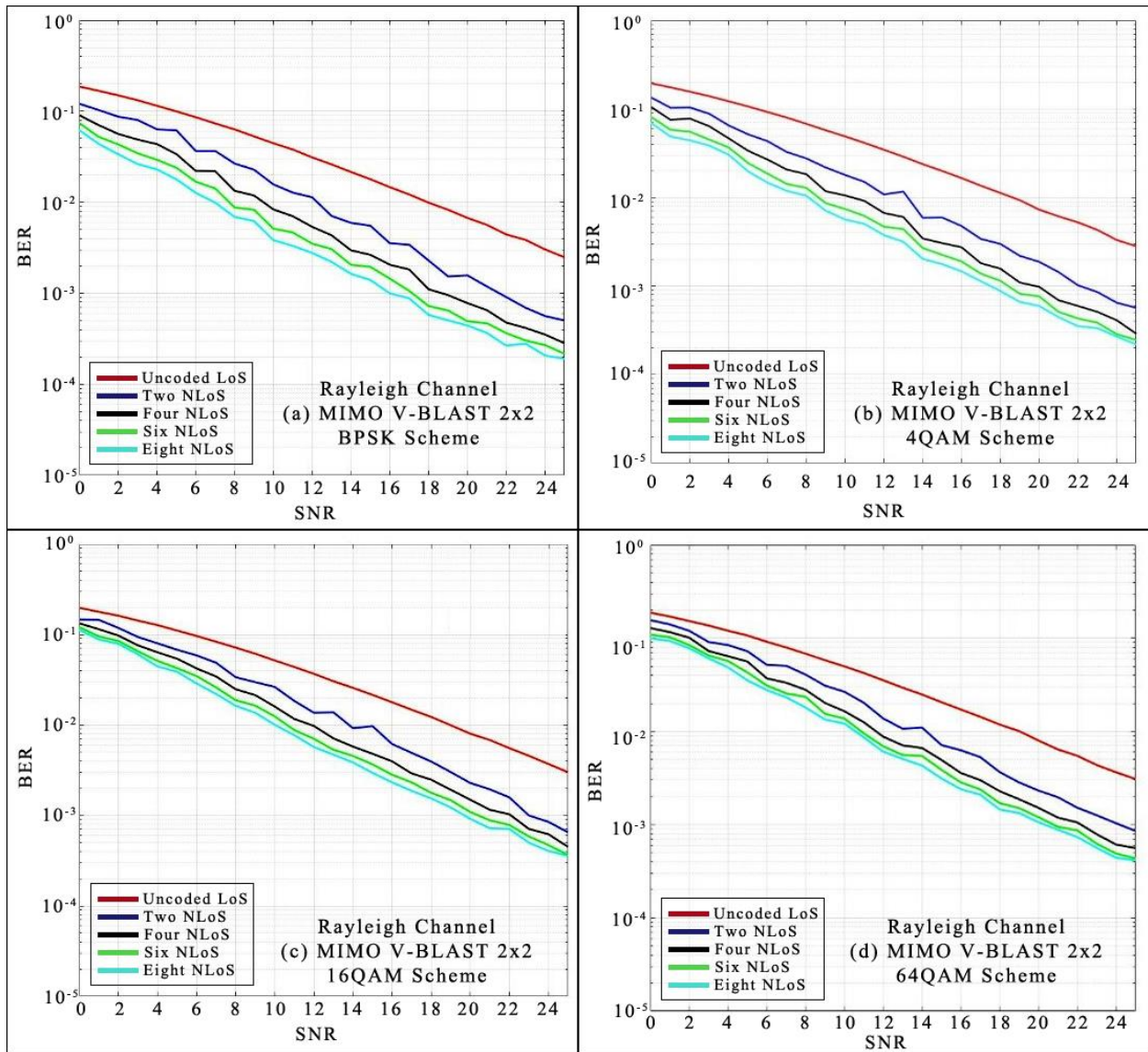

Fig. (2): The Effect of Multipath FEC Technique on the BER Performance for V-BLAST MIMO 2x2 (Rayleigh Channel)

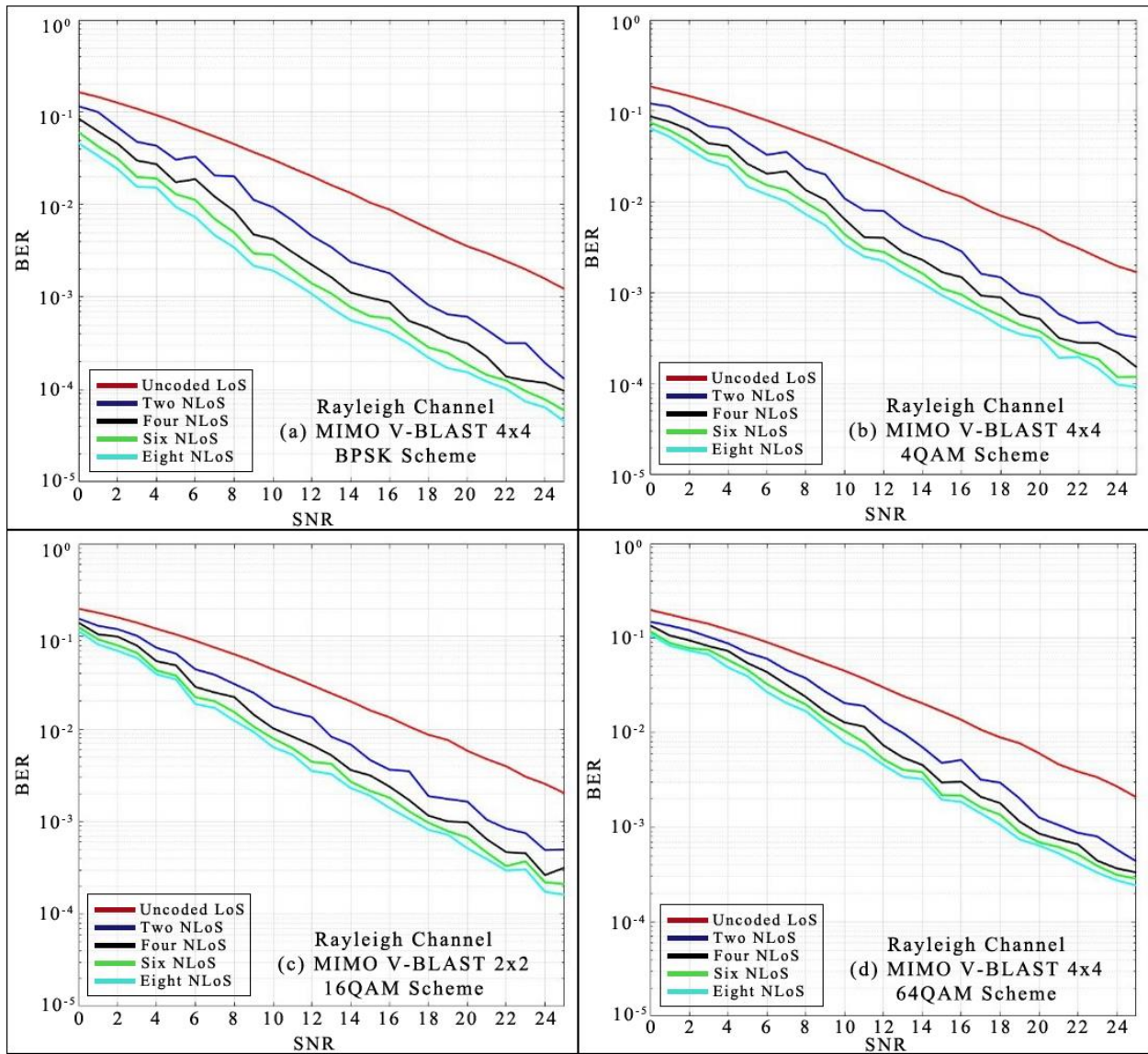

Fig. (3): The Effect of Multipath FEC Technique on the BER Performance for V-BLAST MIMO 4x4 (Rayleigh Channel)

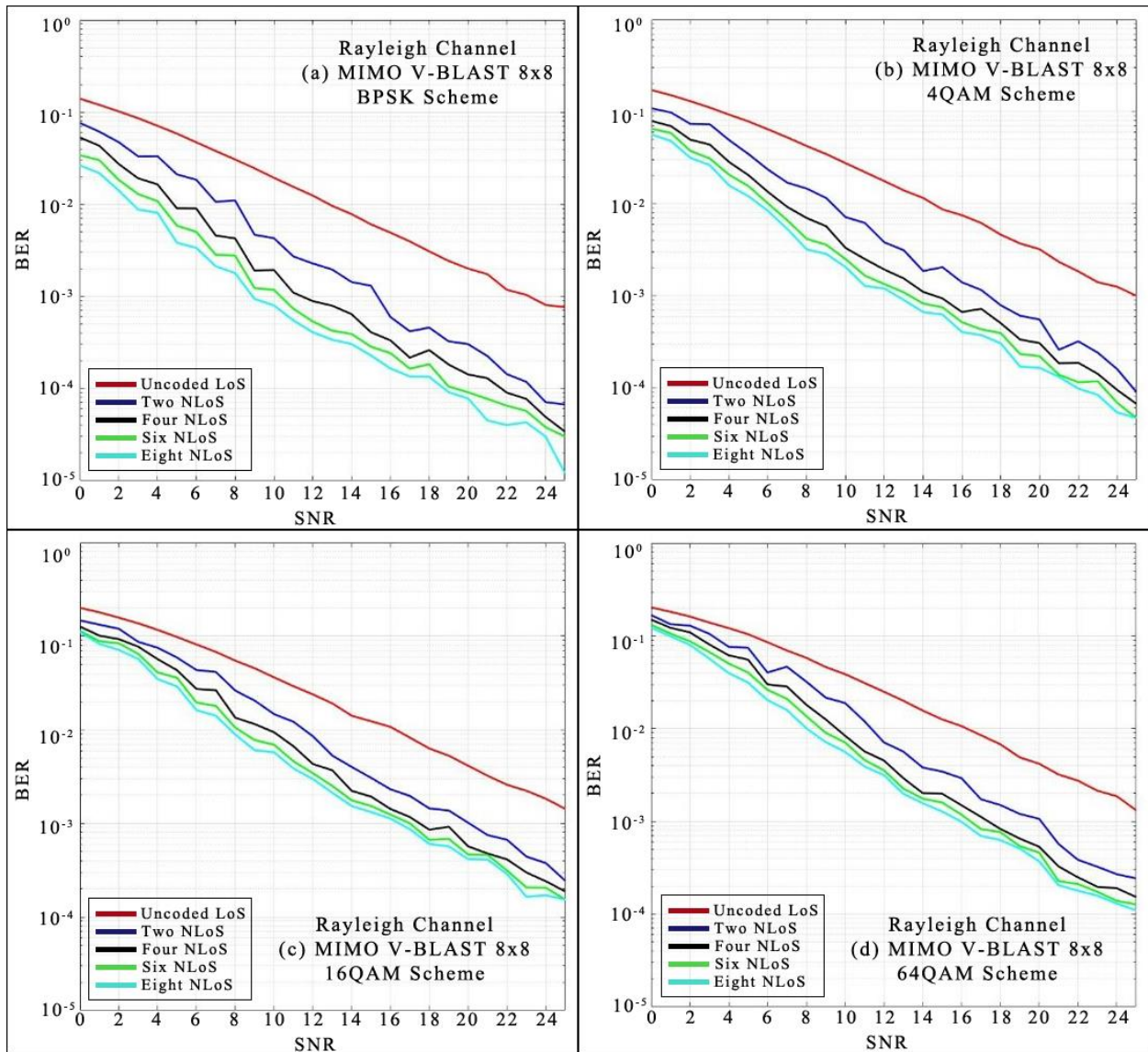

Fig. (4): The Effect of Multipath FEC Technique on the BER Performance for V-BLAST MIMO 8x8 (Rayleigh Channel)

The obtained results in Figures 5, 6 and 7 have also shown remarkable improvement in the BER performance under the *AWGN channel*.

The outcome in Figure 5 demonstrates that the CWMC has the optimum performance with the BPSK and 4QAM modulation scheme for the V-BLAST MIMO 2x2 systems. For instance, the utilising of two multipath replicas improves the BER performance of the system by approximately 2dB, while a 6dB improvement is achieved by providing eight multipath copies at 10⁻³ BER (see Figure 5a). On the other hand, the CWMC combiner gives an inferior performance with 16QAM and 64QAM modulation methods. However, the overall system performance has

been enhanced slightly under these two modulations schemes (see Figures 5c and 5d).

The simulation results in Figures 6 and 7 for V-BLAST MIMO 4x4 and V-BLAST MIMO 8x8 systems have the same pattern as the V-BLAST MIMO 2x2 systems. Where the use of BPSK and 4QAM modulation gives the best performance of the multipath FEC and CWMC techniques, the use of 16QAM and 64QAM schemes show a poorer performance of techniques. Nevertheless, the overall BER performance of the V-BLAST MIMO 4x4 and V-BLAST MIMO 8x8 systems have slightly improved using multipath FEC and CWMC techniques.

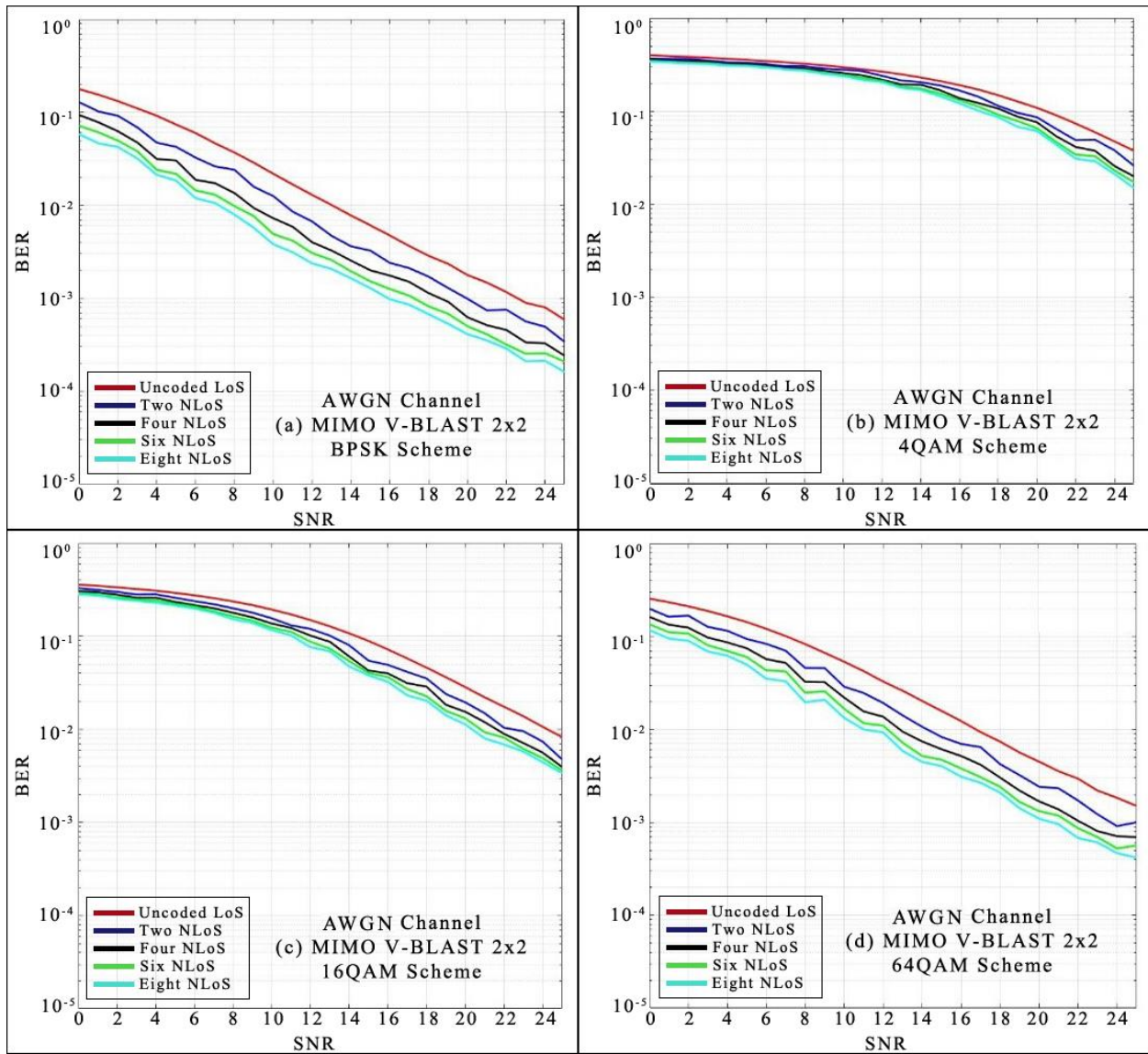

Fig. (5): The Effect of Multipath FEC Technique on the BER Performance for V-BLAST MIMO 2x2 (AWGN Channel)

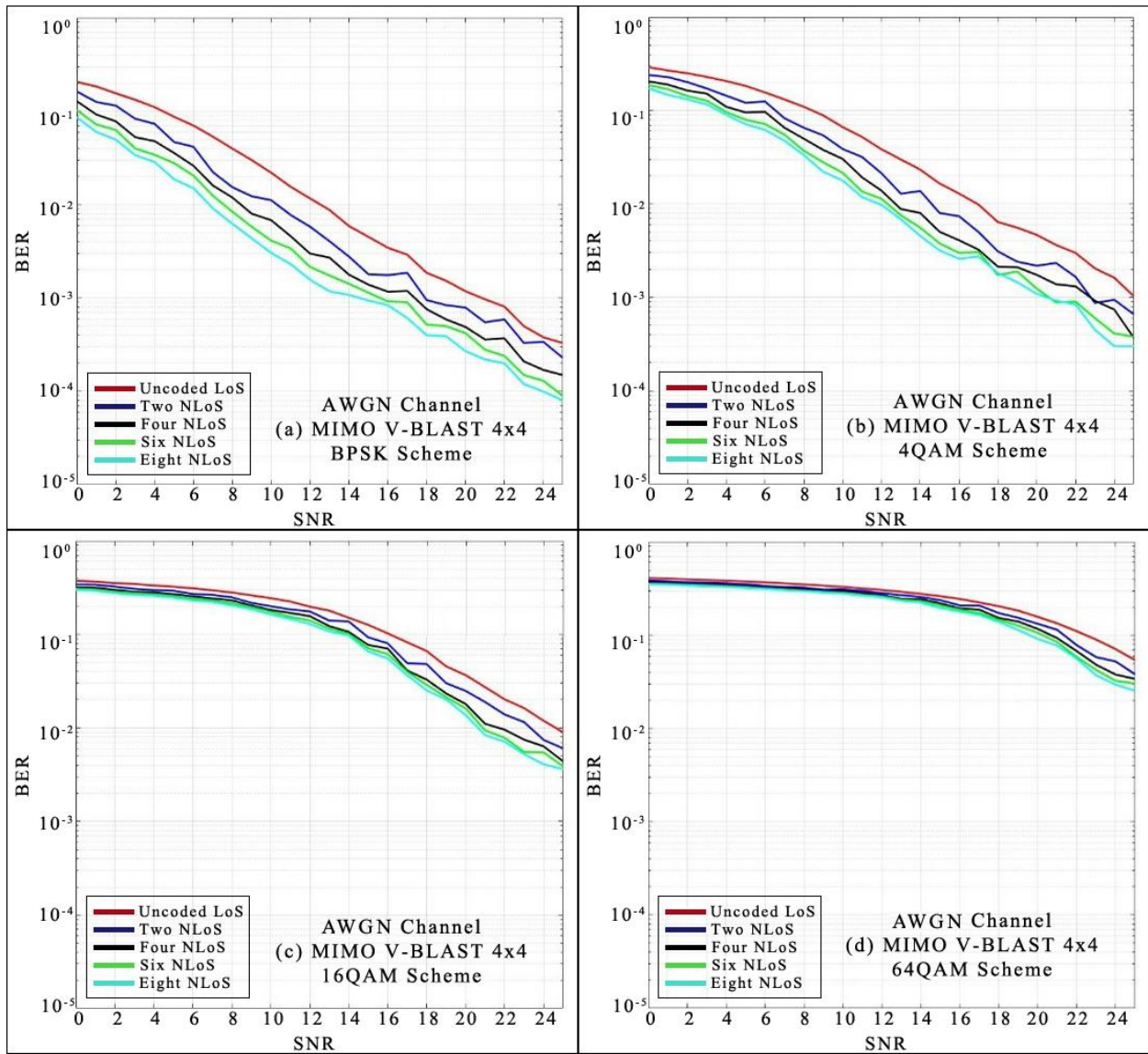

Fig. (6): The Effect of Multipath FEC Technique on the BER Performance for V-BLAST MIMO 4x4 (AWGN Channel)

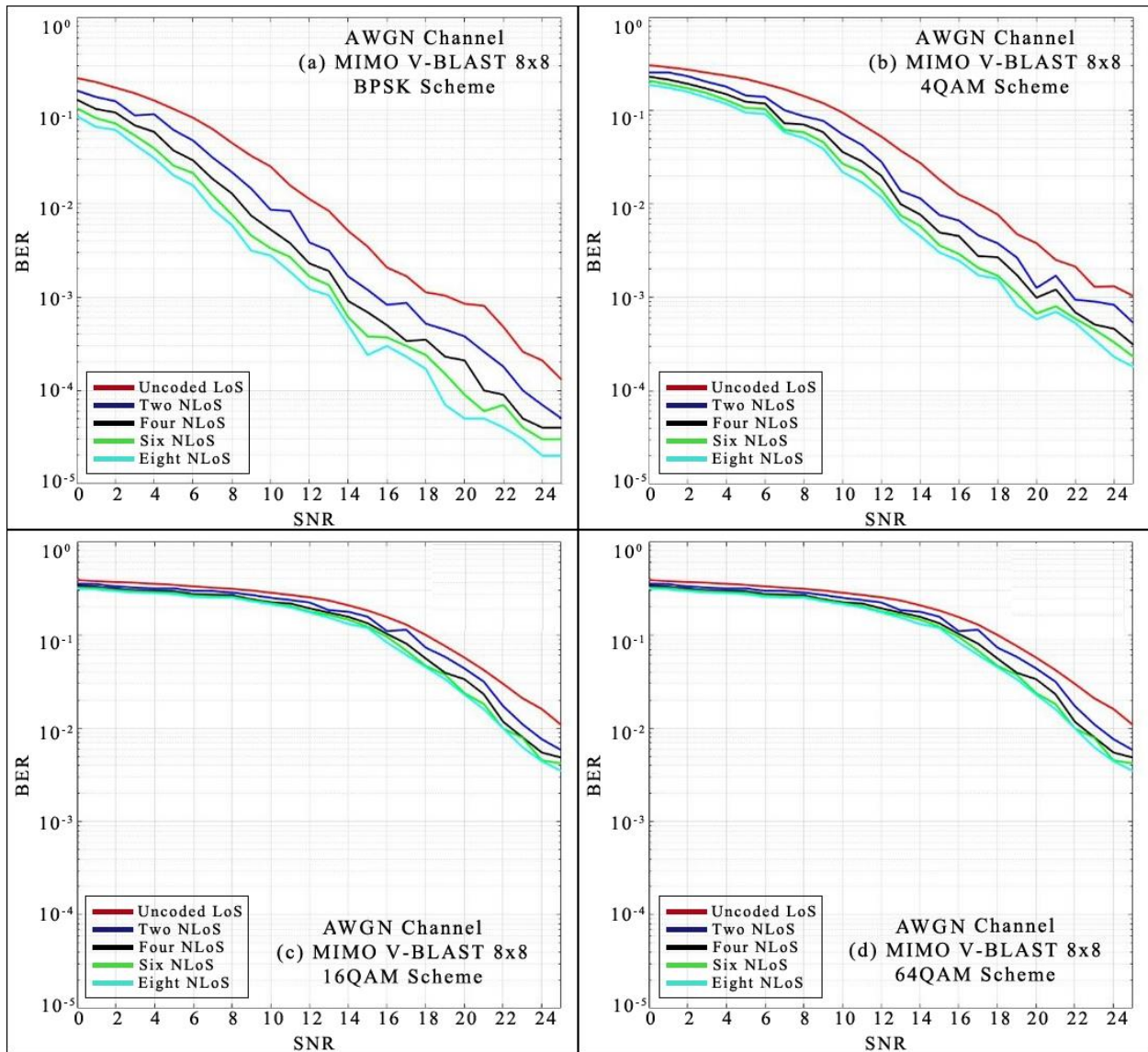

Fig. (7): The Effect of Multipath FEC Technique on the BER Performance for V-BLAST MIMO 8x8 (AWGN Channel)

7. CONCLUSION

The performance of BER has been examined in this paper. The V-BLAST MIMO system with multipath FEC and CWMC processing diversity techniques by using 2x2, 4x4 and 8x8 antennas with BPSK, 4QAM, 16QAM and 64QAM modulation schemes have been simulated and analysed. The obtained results showed that the performance of BER can be improved without overhead by using the existing resources. Furthermore, it reveals that the multipath phenomenon can be considered as an advantage rather than as a disadvantage. The BER performance with the BPSK and 4QAM modulation scheme for the 2x2, 4x4 and 8x8 V-

BLAST MIMO system outperformed under the other modulation schemes. This is achieved by using multipath FEC diversity technique. Multipath FEC technique employs the multipath propagation signals (NLoS) which are considered as redundant copies of the transmitted signal (LoS) to improve the system performance. Moreover, CWMC diversity processing technique that has a low complexity is used to combine NLoS signals with LoS signal. The improvement in the performance of BER can be enhanced more by combining more paths.

8. REFERENCES

- Agarwal, A., & Mehta, S. N. (2018). Development of MIMO-OFDM system and forward error correction techniques since 2000s. *Photonic Network Communications*, 35(1), 65–78. <http://doi.org/10.1007/s11107-017-0716-x>
- Al-Barrak, A., Al-Sherbaz, A., Kanakis, T., & Crockett, R. (2016). Utilisation of Multipath Phenomenon to Improve the Performance of BCH and RS Codes. In *Computer Science and Electronic Engineering (CEEC)* (pp. 6–11). Colchester: IEEE. <http://doi.org/10.1109/CEEC.2016.7835880>
- Al-Barrak, A., Al-Sherbaz, A., Kanakis, T., & Crockett, R. (2017). Enhancing BER Performance Limit of BCH and RS Codes Using Multipath Diversity. *Computers*, 6(2). <http://doi.org/10.3390/computers6020021>
- Al-Khalil, A. B., & Al-Barrak, A. (2018). Performance of BCH and RS Codes in MIMO System Using MPFEC Diversity Technique. In *International Conference on Advanced Science and Engineering (ICOASE)*. Duhok: IEEE. <http://doi.org/10.1109/ICOASE.2018.8548933>
- Aliyu, A., Abdullah, A. H., Sikandar, A., Joda, U. M., Sadiq, F. I., & Ado, A. (2018). Minimizing Route Coupling Effect in Multipath Video Streaming Over Vehicular Network. In G. C. Deka, O. Kaiwartya, P. Vashisth, & P. Rathee (Eds.), *Applications of Computing and Communication Technologies* (pp. 139–151). Delhi: Springer. <http://doi.org/10.1007/978-981-13-2035-4>
- Anbarasi, K., Hemanth, C., & Sangeetha, R. G. (2017). A review on channel models in free space optical communication systems. *Optics and Laser Technology*, 97, 161–171. <http://doi.org/10.1016/j.optlastec.2017.06.018>
- Bae, M., Xue, D., Park, J., & Yoon, J. R. (2015). Multipath Fading Channel Characterization and Performances of Forward Error Correction Codes in Very Shallow Water. *Journal of the Korea Institute of Information and Communication Engineering*, 19(10), 2247–2255. <http://doi.org/10.6109/jkiice.2015.19.10.2247>
- Cai, G., Fang, Y., Han, G., Lau, F. C. M., & Wang, L. (2016). A Square-Constellation-Based M-Ary DCSK Communication System. *IEEE Access*, 4, 6295–6303. <http://doi.org/10.1109/ACCESS.2016.2612224>
- Farzamnia, A., Hlaing, N. W., Kong, L. E., Halder, M. K., & Rezaii, T. Y. (2019). Investigation of error performance in network coded MIMO-VBLAST wireless communication systems. *Journal of ELECTRICAL ENGINEERING*, 70(4), 273–284. <http://doi.org/10.2478/jee-2019>
- Herrero, R. (2017). Modeling and comparative analysis of Forward Error Correction in the context of multipath redundancy. *Telecommunication Systems*, 65(4), 783–794. <http://doi.org/10.1007/s11235-016-0267-y>
- Herrero, R., & Hernandez, D. (2019). Forward error correction in real-time Internet of things CoAP-based wireless sensor networks. *IET Wireless Sensor Systems*, 9(1), 42–47. <http://doi.org/10.1049/iet-wss.2018.5077>
- Jakborvornphan, S. (2019). Fading Characteristics over Wireless Channels. *Journal of Engineering and Applied Sciences*, 15(2), 444–451. <http://doi.org/10.36478/jeasci.2020.444.451>
- Jakes, W. C. (1974). Diversity Techniques. In *Microwave Mobile Communications* (pp. 389–544). Wiley-IEEE Press. <http://doi.org/10.1109/9780470545287.ch6>
- Khatoon, H., & Chidar, R. K. (2019). Simulation and Performance Estimation of BPSK in Rayleigh channel using SC, MRC and EGC diversity techniques. *International Research Journal of Engineering and Technology (IRJET)*, 6(2), 2048–2052. Retrieved from www.irjet.net
- Kumar, S. (2015). *Wireless Communications Fundamental & Advanced Concepts*. Ranchi: River Publishers. Retrieved from https://www.riverpublishers.com/book_details.php?book_id=249
- Milic, M., Krstic, D., Stefanovic, M., & Nikolic, P. (2019). Evaluation of Statistics for Macrodiversity Systems under the Influence of Specific Single Shadowing and Complex Fading. *Journal of Circuits, Systems and*

- Computers, 29(9), 1–13.
<http://doi.org/10.1142/S0218126620501534>
- O. A, E., A. E, A., M. O, O., & K.C, O. (2014). Effective Fading Reduction Techniques in Wireless Communication System. IOSR Journal of Electronics and Communication Engineering, 9(4), 35–43.
<http://doi.org/10.9790/2834-09423543>
- Seferagić, A., Famaey, J., De Poorter, E., & Hoebeke, J. (2020). Survey on wireless technology trade-offs for the industrial internet of things. Sensors (Switzerland), 20(2), 1–22.
<http://doi.org/10.3390/s20020488>
- Uzma, Bhat, G. M., & Sheikh, J. A. (2019). A MIMO-OFDM based secure and robust communication system for IOT driven healthcare. International Journal of Recent Technology and Engineering, 7(6), 1208–1221.
- Zhang, C., Qi, W., Wei, L., Chang, J., & Zhao, Y. (2017). Multipath Error Correction in Radio Interferometric Positioning Systems. IEEE SIGNAL PROCESSING LETTERS, X(X).
- Zhang, K. Q. T. (2015). Diversity Techniques. In Wireless Communications: Principles, Theory and Methodology (pp. 171–206). Wiley. Retrieved from <https://www.wiley.com/en-us/Wireless+Communications%3A+Principles%2C+Theory+and+Methodology-p-9781119113263>